

TMC NO.	A	B	C	D	E	F	G	H	J	K	L	MTG. SCREW	STYLE
PM-823 -1	15/64 R.	15/64 R.	1-3/8	5/16	5/16	C'S 10-32	—	3/8	1/2	10-32 TAP	1/16 R.	SCFP1032BN12	A
PM-823 -2	11/64 R.	11/64 R.	1-1/16	1/4	1/4	C'S 6-32	1/4 R.	1/4	3/8	6-32 TAP	1/32 R.	SCFP0632BN8	B

REVISIONS						
SYM	DESCRIPTION	DATE	E.M.N. NO.	DRAFT	CHKD	APPR
A	STYLE "A" ADDED, STYLE ADDED TO CHART DIM. 1-3/8 WAS 1-1/2, 5/16 WAS 3/8, "G" DELETED ON STYLE "A"	3-25-63	8642			

PM-823

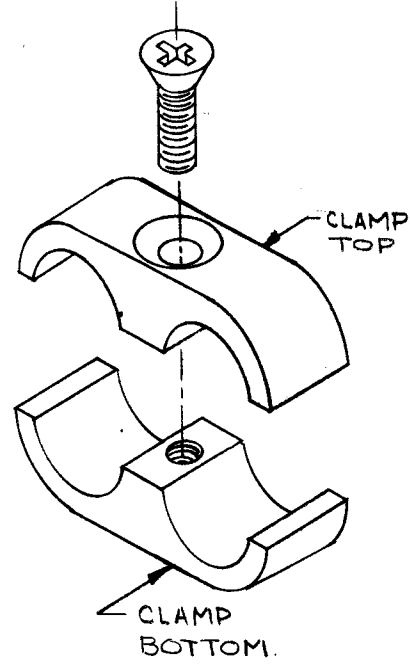
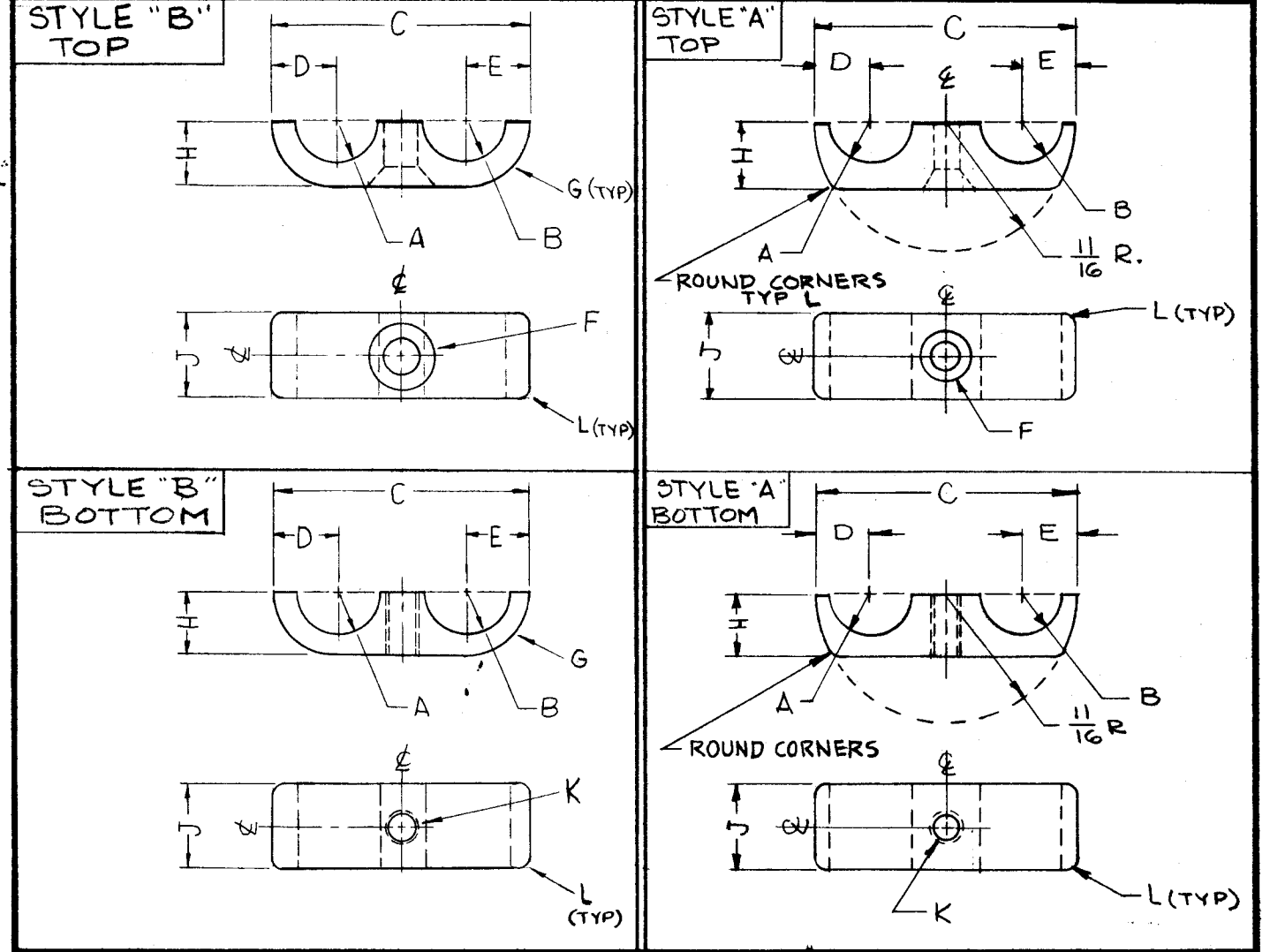

ALL PERSONS RECEIVING THIS DRAWING
 THE TECHNICAL MATERIEL CORPORATION claims
 proprietary right in the material disclosed hereon.
 This drawing is issued in confidence for engineering
 information only and may not be reproduced or used
 to manufacture anything shown hereon without per-
 mission from THE TECHNICAL MATERIEL CORPORA-
 TION to the user. This drawing is loaned for mutual
 assistance and is subject to recall at any time.

Property of:
THE TECHNICAL MATERIEL CORPORATION
 MAMARONECK, NEW YORK

NOTES

1	GPT-10K	
2	GPT-40K	
Q'TY./UNIT	MODEL USED ON	ASS'Y. NO.
SCALE	CODE	
THE CONTENTS OF THIS DRAWING ARE THE EXCLUSIVE PROPERTY OF THE TECHNICAL MATERIEL CORP. ITS UNAUTHORIZED USE OR REPRODUCTION IN WHOLE OR IN PART IS STRICTLY FORBIDDEN.		

REQ'D.	ITEM	PART NUMBER	DESCRIPTION	SYMBOL
LIST OF MATERIAL				
MATERIAL BRASS			THE TECHNICAL MATERIEL CORP. MAMARONECK, NEW YORK	
FINISH SILVER PLATE .0003			TITLE CLAMP	
UNLESS OTHERWISE SPECIFIED DIMENSIONS ARE IN INCHES AND INCLUDE CHEMICALLY APPLIED OR PLATED FINISHES		DRAWN <i>SRG</i>	DATE 2-12-63	FINAL APPROVAL <i>BP</i>
DECIMALS .X ± .05 .XX ± .01 .XXX ± .005		CHECKED	DATE	
FRACTIONS ± 1/64 ANGLES ± 0° 30'		ELECT. DES. <i>SRG</i>	DATE	
TOLERANCES		MECH. DES.	DATE	
			SHEET	REV. LTR.