

PM-766

THE CONTENTS OF THIS DRAWING ARE THE EXCLUSIVE PROPERTY OF THE TECHNICAL MATERIEL CORP. ITS UNAUTHORIZED USE OR REPRODUCTION IN WHOLE OR IN PART IS STRICTLY FORBIDDEN.

NOTICE TO PERSONS RECEIVING THIS DRAWING

THE TECHNICAL MATERIEL CORPORATION claims proprietary right in the material disclosed hereon. This drawing is issued in confidence for engineering information only and may not be reproduced or used to manufacture anything shown hereon without permission from THE TECHNICAL MATERIEL CORPORATION to the user. This drawing is loaned for mutual assistance and is subject to recall at any time.

Property of:  
THE TECHNICAL MATERIEL CORPORATION  
MAMARONECK, NEW YORK

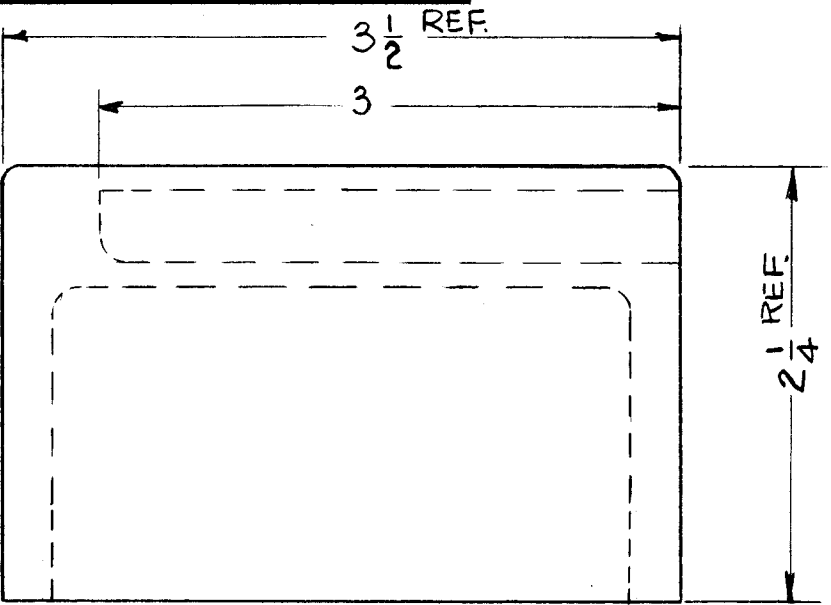

DRILL & TAP 6-32 x 3/8 DEEP  
4 REQ.

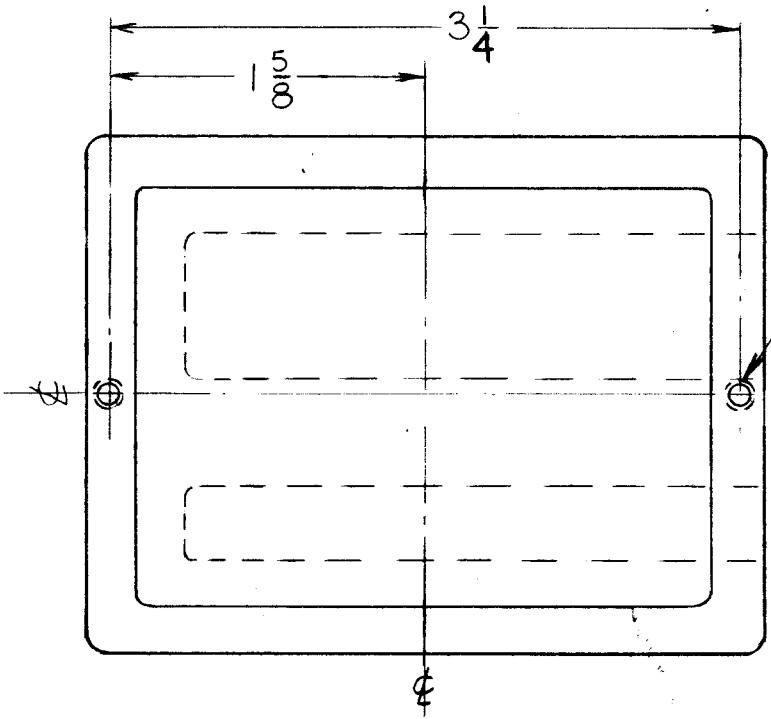

DRILL & TAP 4-40 x 3/8 DEEP  
2 REQ.

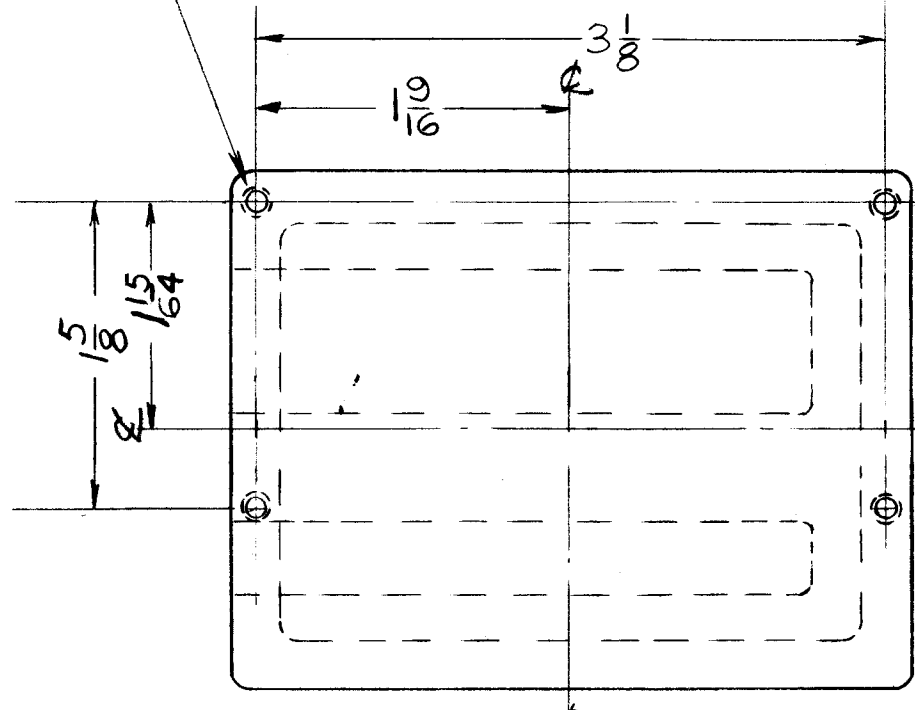
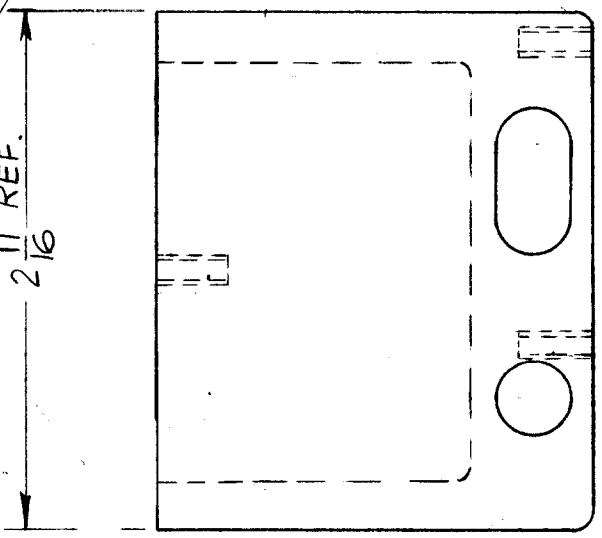

REF: CS-107(1)

REQ.	ITEM	PART NO.	WESCHLER DESCRIPTION	SYMBOL
	CASTING		THE TECHNICAL MATERIEL CORP.	
	STOCK SIZE		MAMARONECK, NEW YORK	
	ALUMINUM		OVEN, MACHINING	
	MATERIAL		OSC. CIRCUIT	
	356-T6		V.R.R.	BP
	TYPE & TEMPER	HEAT TREAT. SPEC.	DRAWN	CHECKED
	5404 YEL. IRIDITE			
	FINISH & SPEC. NO.	ELEC. DES. APP.	MECH. DES. APP.	PM-766

SYM	DESCRIPTION	DATE	CH. NO.	DRAFTS	CHECKER	ENG. APP.
	UNLESS OTHERWISE SPECIFIED:	SCALE: DO NOT SCALE				
	DIMENSIONS ARE IN INCHES	MAXIMUM ALLOWABLE TOLERANCES HAVE BEEN DETERMINED AND ANY DEVIATIONS WILL BE CAUSE FOR REJECTION. REMOVE ALL BURRS AND SHARP EDGES				
	TOLERANCES ON FRACTIONS ± 1/64 DECIMALS ± .005 ANGLES ± 1/2°	2	AFC-3			7-26-62
		REQ. PER UNIT	MODEL	SECTION	ASS'Y. NO.	DATE
			USED ON			