

THE CONTENTS OF THIS DRAWING ARE THE EXCLUSIVE PROPERTY OF THE TECHNICAL MATERIEL CORP. ITS UNAUTHORIZED USE OR REPRODUCTION IN WHOLE OR IN PART IS STRICTLY FORBIDDEN.

PM-740

1 1/4 - 18 NEF - 2A

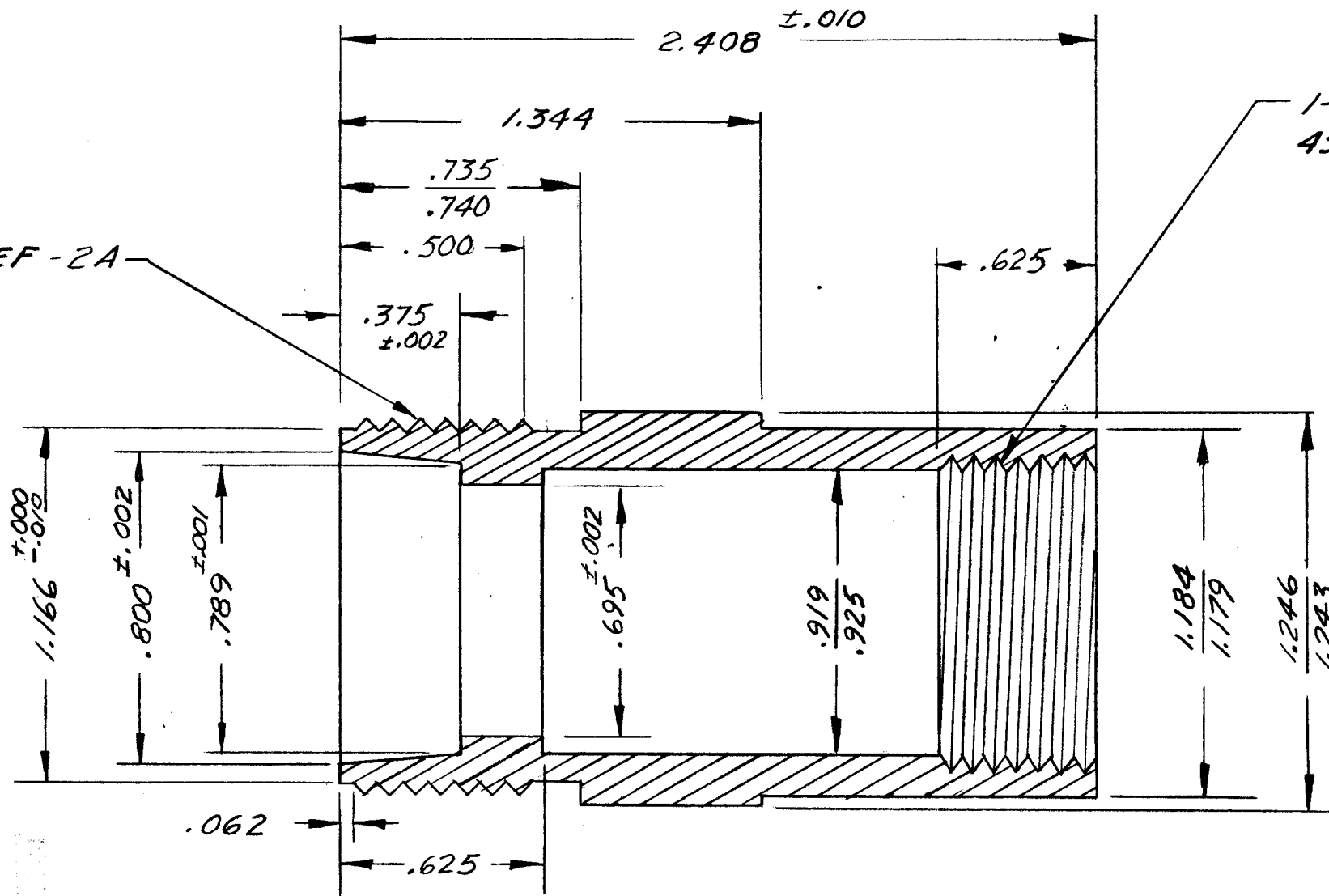

1-14 NF-2 THD. X 1/2 DEEP
45° CHAMFER FIRST THD.

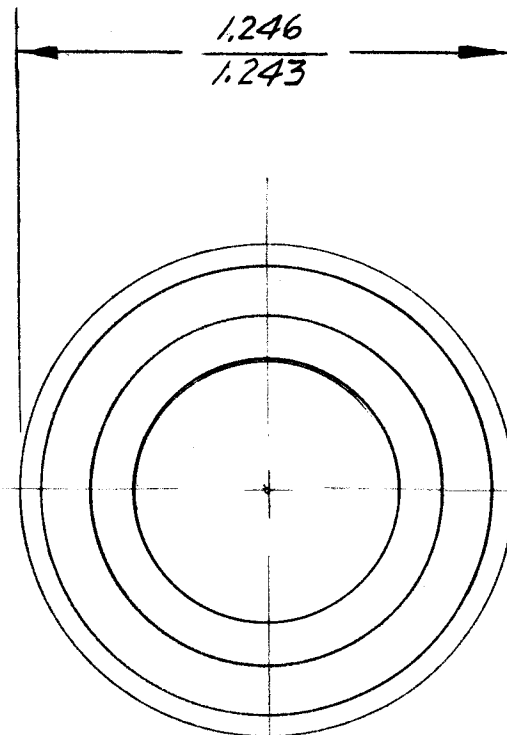

NOTES:

1. DIMENSIONS SHOWN ARE AFTER PLATING.
2. PART TO BE FREE FROM BURRS AND CHIPS.
3. FINISH - SILVER PLATE .0002 AND RHODIUM FLASH.

REF: J-237

THE TECHNICAL MATERIEL CORPORATION claims proprietary right in the herein disclosed herein. This drawing is issued in confidence. No engineering information only and may not be reproduced or used to manufacture any and shown herein without permission from THE TECHNICAL MATERIEL CORPORATION to the user. This drawing is loaned for mutual assistance and is subject to recall at any time.

PROPERTY OF THE TECHNICAL MATERIEL CORPORATION

THE TECHNICAL MATERIEL CORPORATION
MAMARONECK, NEW YORK

REQ.	ITEM	PART NO.	DESCRIPTION	SYMBOL
			THE TECHNICAL MATERIEL CORP. MAMARONECK, NEW YORK	
			BODY, LC RECEPTACLE CONNECTOR	
			BRASS	
			1/2 HARD	
			WR	RUZZO
			SEE NOTE	PM-740
			FINISH & SPEC. NO.	ELEC. DES. APP. MECH. DES. APP.

SYM	DESCRIPTION	DATE	CH. NO.	DRAFTS	CHECKER	ENG. APP.
	UNLESS OTHERWISE SPECIFIED: DIMENSIONS ARE IN INCHES TOLERANCES ON FRACTIONS ± 1/64 DECIMALS ± .005 ANGLES ± 1/2°					
	SCALE: MAXIMUM ALLOWABLE TOLERANCES HAVE BEEN DETERMINED AND ANY DEVIATIONS WILL BE CAUSE FOR REJECTION. REMOVE ALL BURRS AND SHARP EDGES					
		1	TCA-EIA			12-26-61
		REQ. PER UNIT	MODEL	SECTION	ASS'Y. NO.	DATE
			USED ON			