

THE CONTENTS OF THIS DRAWING ARE THE EXCLUSIVE PROPERTY OF THE TECHNICAL MATERIEL CORP. ITS UNAUTHORIZED USE OR REPRODUCTION IN WHOLE OR IN PART IS STRICTLY FORBIDDEN.

REQ. PER UNIT	USED ON		
	MODEL	ASS'Y. NO.	DATE
10	GPT-40K		12-4-61
14	GPT-40K (4) AS-125	AX-339	12-23-63

PM-735 B

SYMBOL	DESCRIPTION	QUANTITY
A	.380 $\begin{smallmatrix} +.001 \\ -.000 \end{smallmatrix}$ Dia.	1
B	.203 Dia.	2

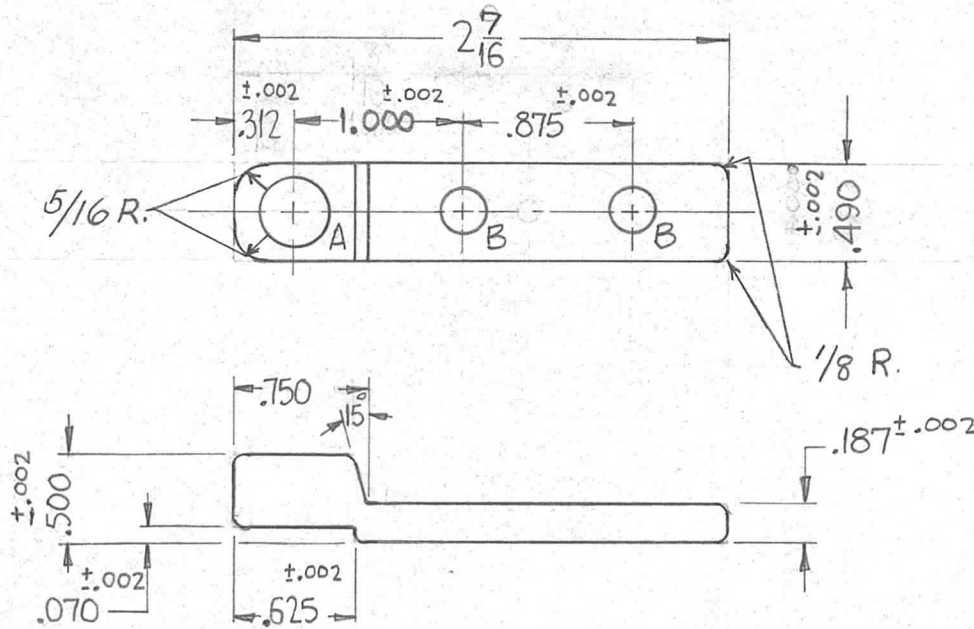

NOTES - UNLESS OTHERWISE NOTED 1/16 RADIUS ON ALL CORNERS. DIM. APPLY AFTER PLATING.

REQ.	ITEM	PART NO.	DESCRIPTION				SYMBOL	
		AS NOTED	THE TECHNICAL MATERIEL CORP.					
		STOCK SIZE	MAMARONECK, NEW YORK					
B	SEE EMN # 10860	2/18/64 10860 A.M. T.R.	BRASS FREE MACHINING				BAR, SUPPORT, CONTACT	
A	DWG UPDATED	12/23/63 10642	MATERIAL					
SYM	DESCRIPTION	DATE	CH. NO.	DRAFTS	CHECKER	ENG. APP.		
UNLESS OTHERWISE SPECIFIED:		SCALE:						
DIMENSIONS ARE IN INCHES		MAXIMUM ALLOWABLE TOLERANCES HAVE BEEN DETERMINED AND ANY DEVIATIONS WILL BE CAUSE FOR REJECTION.						
TOLERANCES ON		REMOVE ALL BURRS AND SHARP EDGES						
FRAC. ± 1/64 DEC. ± .005 ANGLES ± 1/2°								
		TYPE & TEMPER		HEAT TREAT. SPEC.		DRAWN	CHECKED	FINAL APPROVAL
		S 245 SILVER PLATE				DB	all	PM-735 B
		FINISH & SPEC. NO.		ELEC. DES. APP.		MECH. DES. APP.		