

THE CONTENTS OF THIS DRAWING ARE THE EXCLUSIVE PROPERTY OF THE TECHNICAL MATERIEL CORP. ITS UNAUTHORIZED USE OR REPRODUCTION IN WHOLE OR IN PART IS STRICTLY FORBIDDEN.

REQ. PER UNIT	USED ON			PM-718
	MODEL	ASS'Y. NO.	DATE	
	1	AT-103	GPT-40 K	

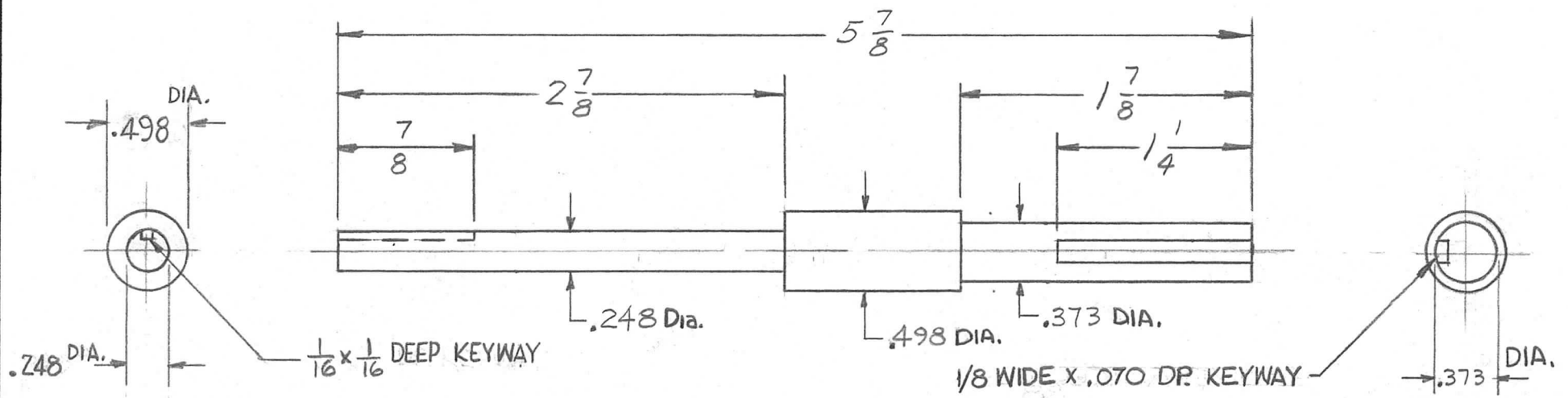

REQ.	ITEM	PART NO.	DESCRIPTION			SYMBOL
		$\frac{1}{2}$ DIA.	THE TECHNICAL MATERIEL CORP.			
		STOCK SIZE	MAMARONECK, NEW YORK			
		STAINLESS STEEL	SHAFT, CAPACITOR			
		MATERIAL				
SYM	DESCRIPTION	DATE	CH. NO.	DRAFTS	CHECKER	ENG. APP.
UNLESS OTHERWISE SPECIFIED: DIMENSIONS ARE IN INCHES TOLERANCES ON FRAC. $\pm 1/64$ DEC. $\pm .005$ ANGLES $\pm 1/20$		SCALE:		MAXIMUM ALLOWABLE TOLERANCES HAVE BEEN DETERMINED AND ANY DEVIATIONS WILL BE CAUSE FOR REJECTION. REMOVE ALL BURRS AND SHARP EDGES		
		303				
		TYPE & TEMPER	HEAT TREAT. SPEC.	DRAWN	CHECKED	FINAL APPROVAL
		S104-PASSIVATE				PM-718
		FINISH & SPEC. NO.	ELEC. DES. APP.	MECH. DES. APP.		