

REQ. PER. UNIT	USED ON			PM-686	A
	MODEL	ASS'Y. NO.	DATE		
1	CHG-1	GEAR ASS'Y	1-24-61		

A~DR. & TAP FOR 6-32 F.H.S. 2 REQ.

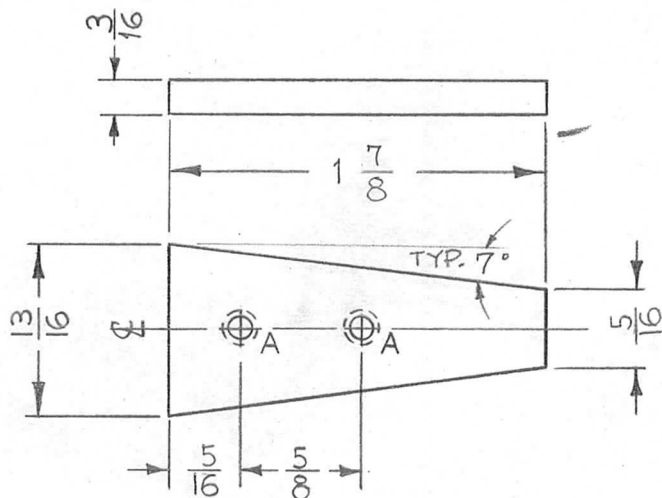

							REQ. ITEM	PART NO.	DESCRIPTION	SYMBOL	
							3/16		THE TECHNICAL MATERIEL CORP. MAMARONECK, NEW YORK STOP, BANDSWITCH		
							STOCK SIZE				
							ALUMINUM				
							MATERIAL				
							2024-T3		W.A.F.	J.W.	SFM
							TYPE & TEMPER	HEAT TREAT. SPEC.	DRAWN	CHECKED	FINAL APPROVAL
							S404 YELL. IRIDITE				PM-686
							FINISH & SPEC. NO.	ELEC. DES. APP	MECH. DES. APP		A
A	1	5/16 Dim. Was 3/8; 1-7/8 Dim. Was 1-15/16; 13/16 Dim. Was 7/8	12-12-61	6035	L.L.	<i>[Signature]</i>	<i>[Signature]</i>				
ISSUE ITEM CHANGED FROM			DATE	CH. NO.	DRAFTS	CHECKER	ENG. APP.				
TOLERANCES			SCALE:								
DEC. DIM. ± FRAC. DIM. ± ANGULAR DIM. ±			MAXIMUM ALLOWABLE TOLERANCES HAVE BEEN DETERMINED AND ANY DEVIATIONS WILL BE CAUSE FOR REJECTION. REMOVE ALL BURRS AND SHARP EDGES								