

REQ. PER. UNIT	USED ON			PM-672
	MODEL	ASSY. NO.	DATE	
1	ACU		10-20-60	

- A -  $\frac{9}{64}$  DIA. 1 REQ.
- B - DR. & TAP FOR 8-32 1 REQ.
- C - DR. & TAP FOR 10-32 1 REQ.

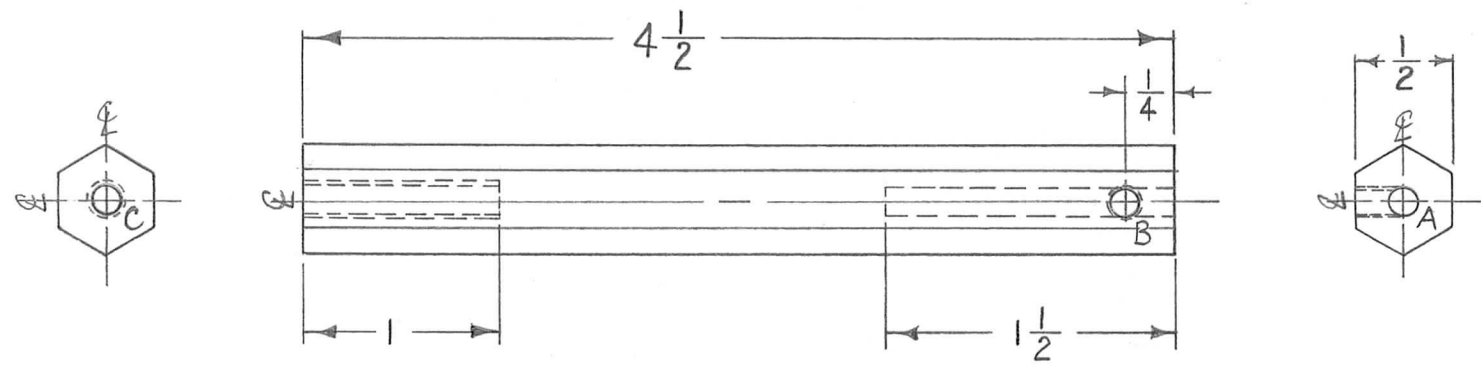

REQ.	ITEM	PART NO.	DESCRIPTION		SYMBOL											
		1/2 HEX.	THE TECHNICAL MATERIEL CORP.													
		STOCK SIZE	MAMARONECK, NEW YORK													
		ALUMINUM	SUPPORT, SPARK GAP.													
		MATERIAL														
ISSUE	ITEM	CHANGED FROM	DATE	CH. NO.	DRAFTS	CHECKER	ENG. APP.	5052-H32		<i>MF</i>	<i>HW</i>	<i>JB</i>				
TOLERANCES			SCALE:					TYPE & TEMPER	HEAT TREAT. SPEC.	DRAWN	CHECKED	FINAL APPROVAL				
DEC. DIM. $\pm$			MAXIMUM ALLOWABLE TOLERANCES HAVE BEEN DETERMINED AND ANY DEVIATIONS WILL BE CAUSE FOR REJECTION. REMOVE ALL BURRS AND SHARP EDGES					3404 YELL. IRIDITE			<i>aa</i>	PM-672				
FRAC. DIM. $\pm$ 1/64													FINISH & SPEC. NO.	ELEC. DES. APP	MECH. DES. APP	
ANGULAR DIM. $\pm$																