

REQ. PER UNIT	USED ON			PM-669
	MODEL	ASS'Y. NO.	DATE	
1	CHG-1	GEAR PL	9-28-60	

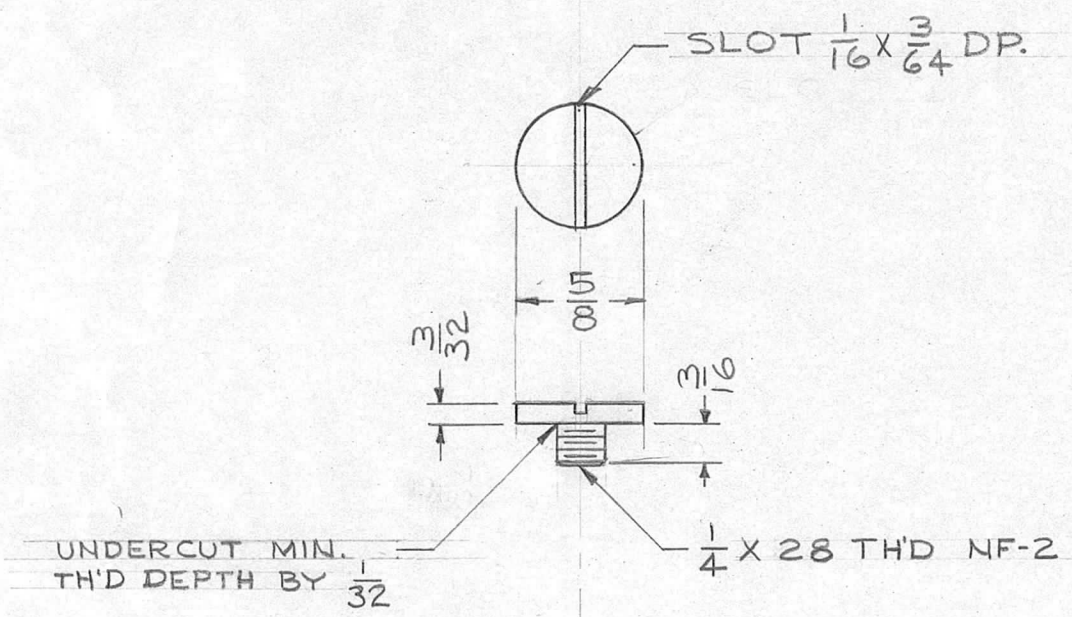

				REQ. ITEM	PART NO.	DESCRIPTION	SYMBOL
						THE TECHNICAL MATERIEL CORP.	
						MAMARONECK, NEW YORK	
					STOCK SIZE	STOP SCREW, GEAR	
					BRASS		
					MATERIAL		
ISSUE	ITEM	CHANGED FROM	DATE	CH. NO.	DRAFTS	CHECKER	ENG. APP.
TOLERANCES			SCALE: #				
DEC. DIM. ±			MAXIMUM ALLOWABLE TOLERANCES HAVE BEEN DETERMINED AND ANY DEVIATIONS WILL BE CAUSE FOR REJECTION. REMOVE ALL BURRS AND SHARP EDGES				
FRAC. DIM. ± 1/64							
ANGULAR DIM. ±							
				HALF HARD		CU	Wde
				TYPE & TEMPER	HEAT TREAT. SPEC.	DRAWN	CHECKED
				NICKEL PLATED .0002			
				FINISH & SPEC. NO.		ELEC. DES. APP	MECH. DES. APP
							PM-669