

REQ. PER UNIT	USED ON			PM-621
	MODEL	ASS'Y. NO.	DATE	
1	AT-101(40K)		3-12-60	

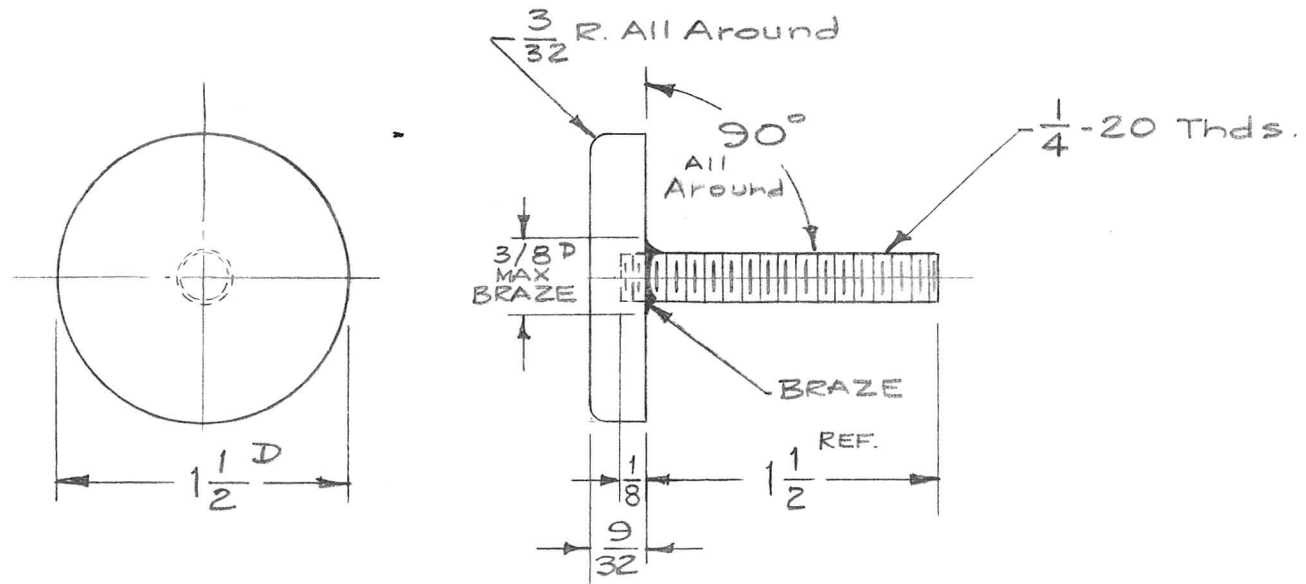

REQ.	ITEM	PART NO.	DESCRIPTION		SYMBOL							
			THE TECHNICAL MATERIEL CORP.									
			MAMARONECK, NEW YORK									
			BUTTON, CONTACT, SIDE									
			(ANTENNA TUNER)									
ISSUE	ITEM	CHANGED FROM	DATE	CH. NO.	DRAFTS	CHECKER	ENG. APP.					
TOLERANCES			SCALE: FULL									
DEC. DIM. ±			MAXIMUM ALLOWABLE TOLERANCES HAVE BEEN DETERMINED AND ANY DEVIATIONS WILL BE CAUSE FOR REJECTION. REMOVE ALL BURRS AND SHARP EDGES					TYPE & TEMPER	HEAT TREAT. SPEC.	DRAWN	CHECKED	FINAL APPROVAL
FRAC. DIM. ± 1/64								FINISH & SPEC. NO.	ELEC. DES. APP	MECH. DES. APP		
ANGULAR DIM. ±											PM-621	