

REQ. PER UNIT	USED ON			PM-616	B
	MODEL	ASS'Y. NO.	DATE		
1	GPT-40K	AX-209	3-1-60		

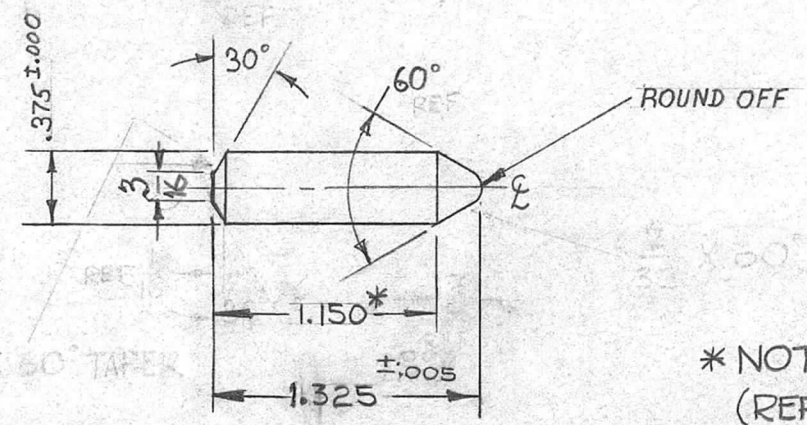
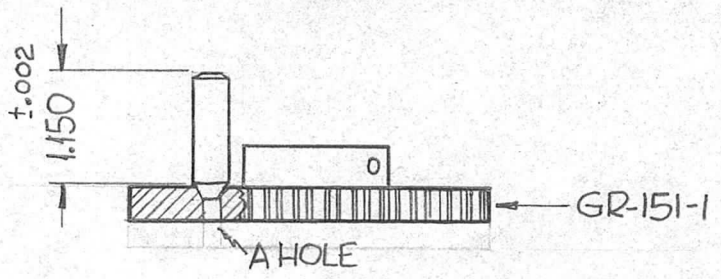

* NOTE ~ THE ASS'Y MEASUREMENT (REF A HOLES GR-151-1) MUST BE 1.150 ±.002.

REQ.	ITEM	PART NO.	DESCRIPTION			SYMBOL
		3/8 D.	THE TECHNICAL MATERIEL CORP.			
		STOCK SIZE	MAMARONECK, NEW YORK			
		STAINLESS STEEL	SHAFT, LOCK			
		MATERIAL				
		# 303				
		TYPE & TEMPER	HEATTREAT. SPEC.	DRAWN	CHECKED	FINAL APPROVAL
		PASSIVATE				
		FINISH & SPEC. NO.	ELEC. DES. APP	MECH. DES. APP		
					PM-616	B

ISSUE	ITEM	CHANGED FROM	DATE	CH. NO.	DRAFTS	CHECKER	ENG. APP.
B	3	TOLERANCES CHANGED	11-17-60	3518		JCR	QJB
	2	DETAIL ADDED					
	1	NOTE ADDED					
A	2	ADD 1.150 DIM.	3-23-60	*		CS	16
	1	ADD 1.325 DIM.					

TOLERANCES (UNLESS OTHERWISE SPECIFIED)		SCALE:
DEC. DIM. ±		MAXIMUM ALLOWABLE TOLERANCES HAVE BEEN DETERMINED AND ANY DEVIATIONS WILL BE CAUSE FOR REJECTION. REMOVE ALL BURRS AND SHARP EDGES
FRAC. DIM. ± 1/64		
ANGULAR DIM. ± 0.20		