

| | | | | |
|----------------|---------|------------|---------|----------|
| REQ. PER. UNIT | USED ON | | | PM-579 A |
| | MODEL | ASS'Y. NO. | DATE | |
| 1 | TU-2 | ATS-50(70) | 6-17-59 | |

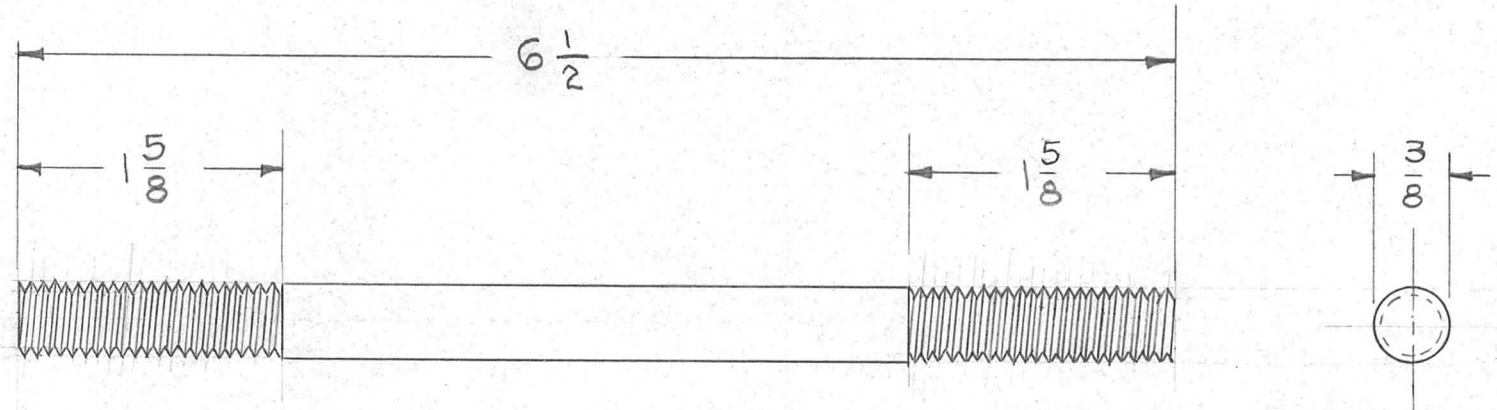

3/8-16 THREADS
CL. 2
(BOTH ENDS)

FINISH:
SILVER PLATE .0002
S-423 IRIDITE, SILVER KOTE

| | | | | | | | | REQ. ITEM | PART NO. | DESCRIPTION | SYMBOL | | | | | | |
|----------------|------|-----------------|--|---------|--------|---------|-----------|--------------------|------------------|------------------------------|---------|----------------|--|--|----------------|----------------|----------|
| | | | | | | | | 3/8 | | THE TECHNICAL MATERIEL CORP. | | | | | | | |
| | | | | | | | | STOCK SIZE | | MAMARONECK, NEW YORK | | | | | | | |
| A | 1 | 1 5/8 WAS 1 3/8 | 3-25-64 | 11109 | A.M. | @ | lb | BRASS | ROD, FEED THRU | | | | | | | | |
| ISSUE | ITEM | CHANGED FROM | DATE | CH. NO. | DRAFTS | CHECKER | ENG. APP. | MATERIAL | | | | | | | | | |
| TOLERANCES | | | SCALE: | | | | | FREE MACHINING | | | | | | | | | |
| DEC. DIM. ± | | | MAXIMUM ALLOWABLE TOLERANCES HAVE BEEN DETERMINED AND ANY DEVIATIONS WILL BE CAUSE FOR REJECTION. REMOVE ALL BURRS AND SHARP EDGES | | | | | TYPE & TEMPER | HEATTREAT. SPEC. | DRAWN | CHECKED | FINAL APPROVAL | | | | | |
| FRAC. DIM. ± | | | | | | | | SEE NOTE | | | | | | | | | |
| ANGULAR DIM. ± | | | | | | | | FINISH & SPEC. NO. | | | | | | | ELEC. DES. APP | MECH. DES. APP | PM-579 A |