

REQ. PER. UNIT	USED ON			PM-576	A
	MODEL	ASS'Y. NO.	DATE		
2	ATS-50(70)T02		6-12-59		

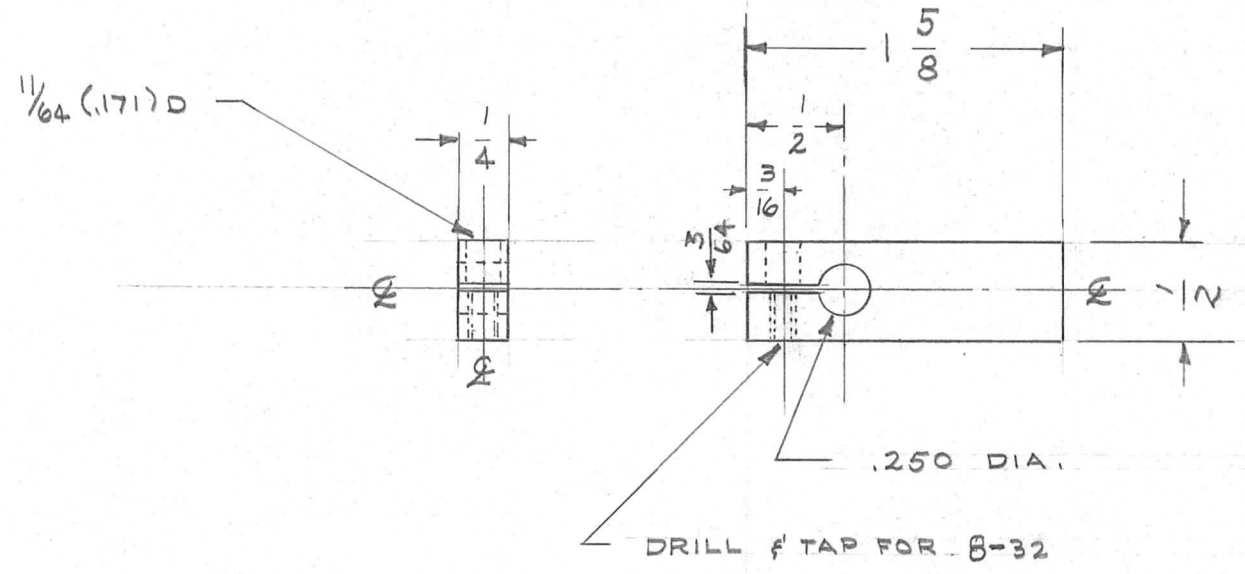

REQ.	ITEM	PART NO.	DESCRIPTION			SYMBOL	
		1/2 X 1/4 BAR	THE TECHNICAL MATERIEL CORP.				
		STOCK SIZE	MAMARONECK, NEW YORK				
		ALUMINUM	SWITCH INDEX				
		MATERIAL					
A	DIM. 3/64 WAS 1/32; DRILL & TAP FOR 8-32 WAS FOR 6-32	2-17-65	13544	J.L.	JOB	AMP	
ISSUE	ITEM	CHANGED FROM	DATE	CH. NO.	DRAFTS	CHECKER	ENG. APP.
TOLERANCES			SCALE: FULL				
DEC. DIM. ± .002			MAXIMUM ALLOWABLE TOLERANCES HAVE BEEN DETERMINED AND ANY DEVIATIONS WILL BE CAUSE FOR REJECTION. REMOVE ALL BURRS AND SHARP EDGES				
FRAC. DIM. ± 1/64							
ANGULAR DIM. ±							
5052-H32		HEATTREAT. SPEC.	DRAWN		CHECKED	FINAL APPROVAL	
S 404 YELLOW IRIDITE			ELEC. DES. APP		MECH. DES. APP	PM-576 A	
FINISH & SPEC. NO.		ELEC. DES. APP		MECH. DES. APP			