

PM-504
A

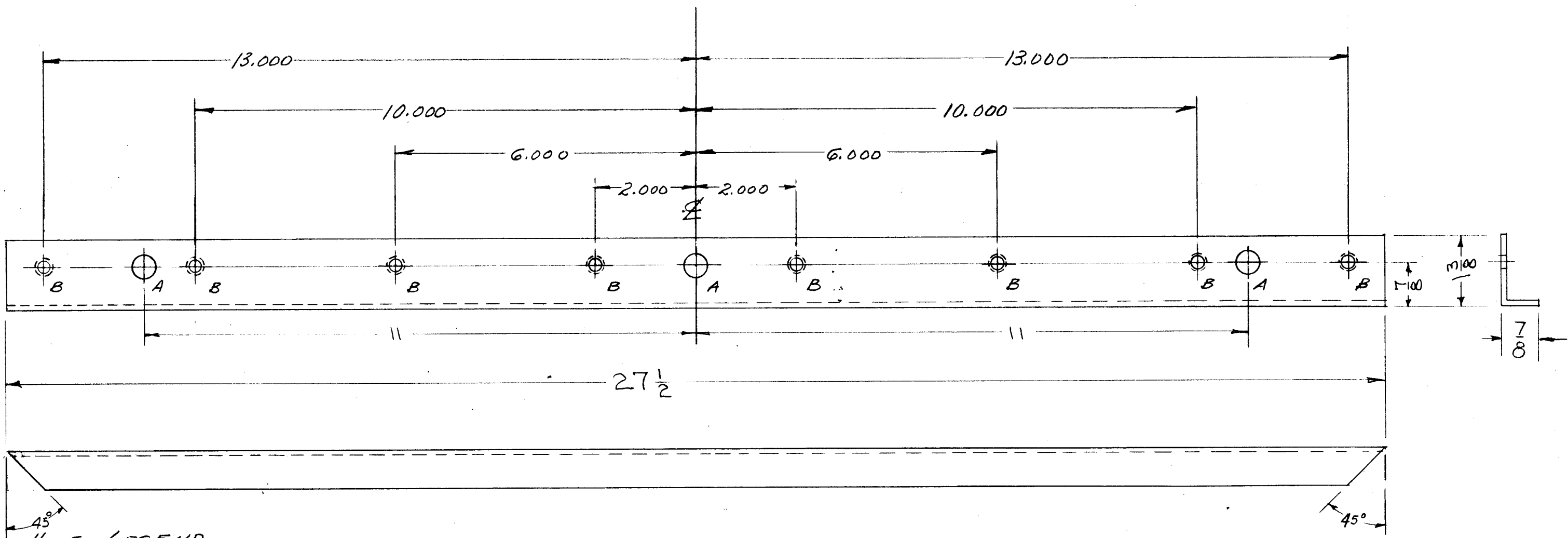

HOLE LEGEND
 A - 1/2 (.500) DIA. 3 REQ.
 B - DRILL & TAP 10-32 8 REQ. CL. 2

NOTICE TO PERSONS RECEIVING THIS DRAWING
 THE TECHNICAL MATERIEL CORPORATION claims proprietary right in the material disclosed hereon. This drawing is issued in confidence for engineering information only and may not be reproduced or used to manufacture anything shown hereon without permission from THE TECHNICAL MATERIEL CORPORATION to the user. This drawing is loaned for mutual assistance and is subject to recall at any time.
 Property of:
 THE TECHNICAL MATERIEL CORPORATION
 MAMARONECK, NEW YORK

REF. MS-1335

ISSUE	ITEM	CHANGED FROM	DATE	CH. NO.	DRAFTS	CHECKER	ENG. APP.
A	1	STOCK SIZE WAS 1 3/8 x 3/4 x 1/8	9/30/58	1	file	file	file
TOLERANCES		SCALE: 1/2					
DEC. DIM. ± .0025		MAXIMUM ALLOWABLE TOLERANCES HAVE BEEN DETERMINED AND ANY DEVIATIONS WILL BE CAUSE FOR REJECTION.					
FRAC. DIM. ± 1/64		REMOVE ALL BURRS AND SHARP EDGES					
ANGULAR DIM. ±							

REQ. PER UNIT	MODEL	PROJECT NO.	ASSY. NO.	DATE
1	RTY-2			10-20-58
1	RTM-2			
1	RTX-2	E-1041		9-16-58
USED ON				

REQ. ITEM	PART NO.	DESCRIPTION	SYMBOL
1 3/8 x 7/8 x 1/8	A	THE TECHNICAL MATERIEL CORP. MAMARONECK, NEW YORK	
STOCK SIZE		TOP STIFFENER, FRONT PANEL	
STEEL			
MATERIAL			
COLD ROLLED		9-16-58	file
TYPE & TEMPER	HEAT TREAT. SPEC.	DRAWN	CHECKED
CAD PLATE .0002		RFB	file
FINISH & SPEC. NO.	ELEC. DES. APP.	MECH. DES. APP.	
			PM-504 A