

STANDARD DRAWING

REQ. PER UNIT	USED ON			PM-454	B
	MODEL	ASS'Y. NO.	DATE		

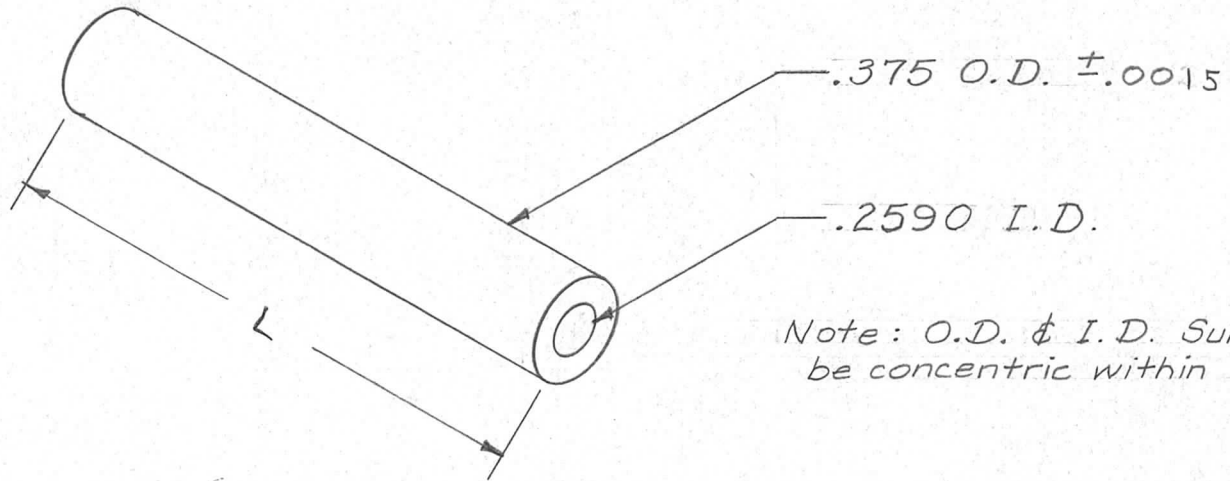

NOMENCLATURE SHALL BE IN THE FOLLOWING FORM

EXAMPLES:

PM-454 - .75 = SHAFT 3/4" LONG
 PM-454 - 1.75 = SHAFT 1 3/4" LONG

PM-454 - "L"

TMC DWG. NO.

LENGTH (IN INCHES)
 (SEE EXAMPLES)

Ref - T.E. CONKLIN # 15 B & S HARD ROUND

REQ. UNIT	ITEM	PART NO.	DESCRIPTION				SYMBOL
		3/8 O.D.	THE TECHNICAL MATERIEL CORP.				
		STOCK SIZE	MAMARONECK, NEW YORK				
B	1	.375 ± .0015 WAS .375 ± .002	1/18/60	1781	W.F.	J.W.	J.W.
A	1	Nomenclature Clarified	1/21/57	1	J.W.	J.W.	J.W.
ISSUE	ITEM	CHANGED FROM	DATE	CH. NO.	DRAFTS	CHECKER	ENG. APP.
TOLERANCES			SCALE:				
DEC. DIM. ±			MAXIMUM ALLOWABLE TOLERANCES HAVE BEEN DETERMINED AND ANY DEVIATIONS WILL BE CAUSE FOR REJECTION.				
FRAC. DIM. ±			REMOVE ALL BURRS AND SHARP EDGES				
ANGULAR DIM. ±							
FREE TURNING		#	167-18-57	J.W.	J.W.	J.W.	J.W.
TYPE & TEMPER		HEAT TREAT. SPEC.	DRAWN	CHECKED	FINAL APPROVAL		
FINISH & SPEC. NO.		ELEC. DES. APP.	MECH. DES. APP.	PM-454			
					B		