

ALL PERSONS RECEIVING THIS DRAWING
 THE TECHNICAL MATERIEL CORPORATION claims
 proprietary right in the material disclosed hereon.
 This drawing is issued in confidence for engineering
 information only and may not be reproduced or used
 to manufacture anything shown hereon without per-
 mission from THE TECHNICAL MATERIEL CORPORA-
 TION to the user. This drawing is loaned for mutual
 assistance and is subject to recall at any time.

Property of:
 THE TECHNICAL MATERIEL CORPORATION
 MAMARONECK, NEW YORK

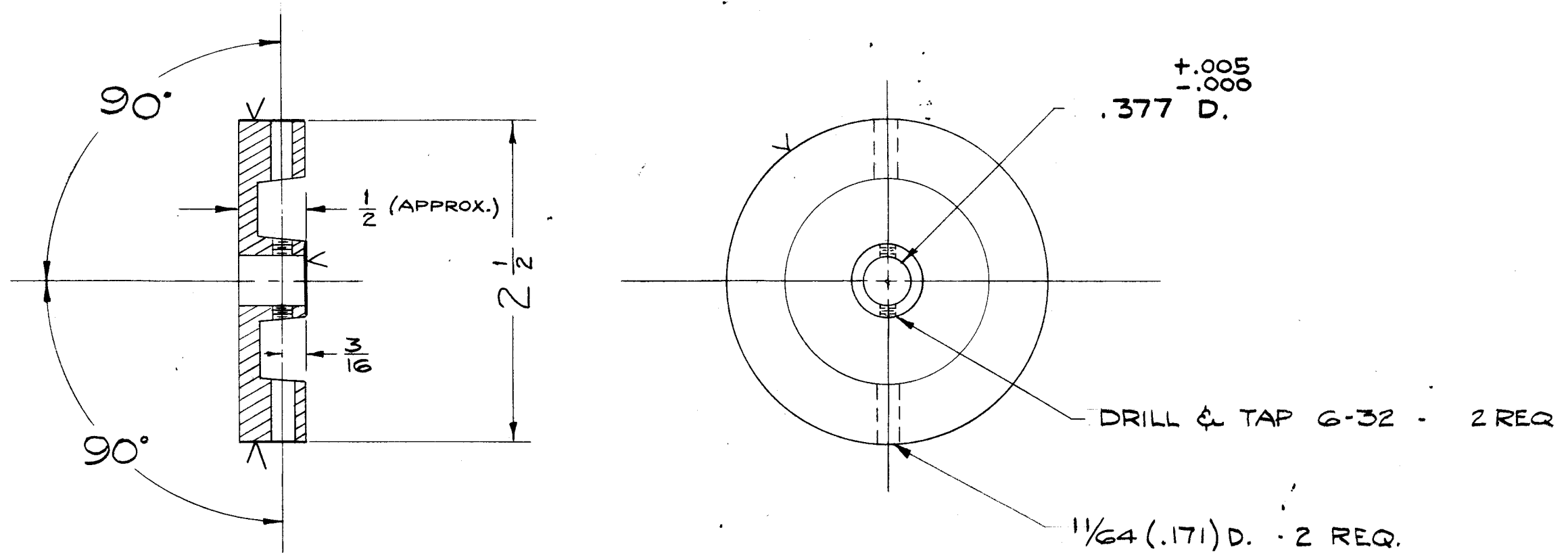

Note - Finish Surfaces Indicated With "V"

REF. DWG. CS-121

ISSUE	ITEM	CHANGED FROM	DATE	CH. NO.	DRAFTS	CHECKER	ENG. APP.
B	1	TOL. ADD. TO .377 D.	1.28.65	13375	hfb	@	[Signature]
A	1	VOX-Z added	6/17/59	1119	JCB	[Signature]	[Signature]
TOLERANCES		SCALE:					
DEC. DIM. ±		MAXIMUM ALLOWABLE TOLERANCES HAVE BEEN DETERMINED AND ANY DEVIATIONS WILL BE CAUSE FOR REJECTION.					
FRAC. DIM. ± 1/64		REMOVE ALL BURRS AND SHARP EDGES					
ANGULAR DIM. ±							

REQ. PER UNIT	MODEL	PROJECT NO.	ASS'Y. NO.	DATE
1	SBE-3	AP-100	A-1517	11-30-59
1	SBE-1	380	A-1517	7-18-57
USED ON				

REQ. ITEM	PART NO.	DESCRIPTION	SYMBOL
	CS-121	THE TECHNICAL MATERIEL CORP. MAMARONECK, NEW YORK	
	STOCK SIZE		
	BRASS	MACHINING, INERTIA WHEEL	
	MATERIAL	SBE-1	
		7-18-57	[Signature]
TYPE & TEMPER	HEAT TREAT. SPEC.	DRAWN	CHECKED
		[Signature]	[Signature]
FINISH & SPEC. NO.	ELEC. DES. APP.	MECH. DES. APP.	
			PM-453 B