

TMC NO.	DIM. A	DIM. B	USED ON	QUAN.	ASS'Y.	REQ. PER UNIT	USED ON			PM-452	B
							MODEL	ASS'Y. NO.	DATE		
PM-452	3/8	15/16	SBE-1	1	A-1487				12-2-57		
PM-452-1	1/4	13/16	SBE-2	1	A-1517	1	SBE-2		5-5-58		
						1 (-1)	SBE-3	AP-100	11-30-59		

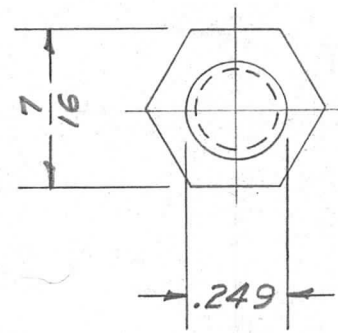
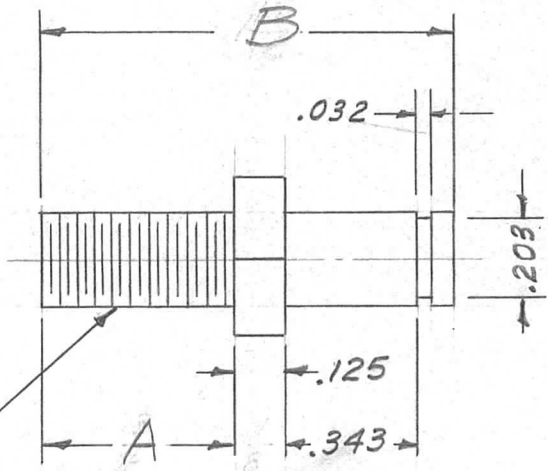

1/4-28 N.F. Cl. 2 Thds.

REQ.	ITEM	PART NO.	DESCRIPTION				SYMBOL
		7/16 HEX	THE TECHNICAL MATERIEL CORP.				
		STOCK SIZE	MAMARONECK, NEW YORK				
B	1	MADE INTO FAMILY Pm-452-1 Added	3/18/58	2	16	HADE	PMO
A	1	REDRAWN - CHANGED	12/2/57	1	16	HADE	PMO
ISSUE ITEM CHANGED FROM			DATE	CH. NO.	DRAFTS	CHECKER	ENG. APP.
TOLERANCES			SCALE: 2X				
DEC. DIM. ± .0015			MAXIMUM ALLOWABLE TOLERANCES HAVE BEEN DETERMINED AND ANY DEVIATIONS WILL BE CAUSE FOR REJECTION.				
FRAC. DIM. ± 1/64			REMOVE ALL BURRS AND SHARP EDGES				
ANGULAR DIM. ±							
Free Turning		— H —	16/12/2/57	HADE	PMO		
TYPE & TEMPER		HEAT TREAT. SPEC.	RE'DRAWN	CHECKED	FINAL APPROVAL		
FINISH & SPEC. NO.		ELEC. DES. APP.	MECH. DES. APP.	PM-452		B	