

REQ. PER UNIT	USED ON			PM-443	A
	MODEL	ASS'Y. NO.	DATE		
R	A-1279	GP1-750D			

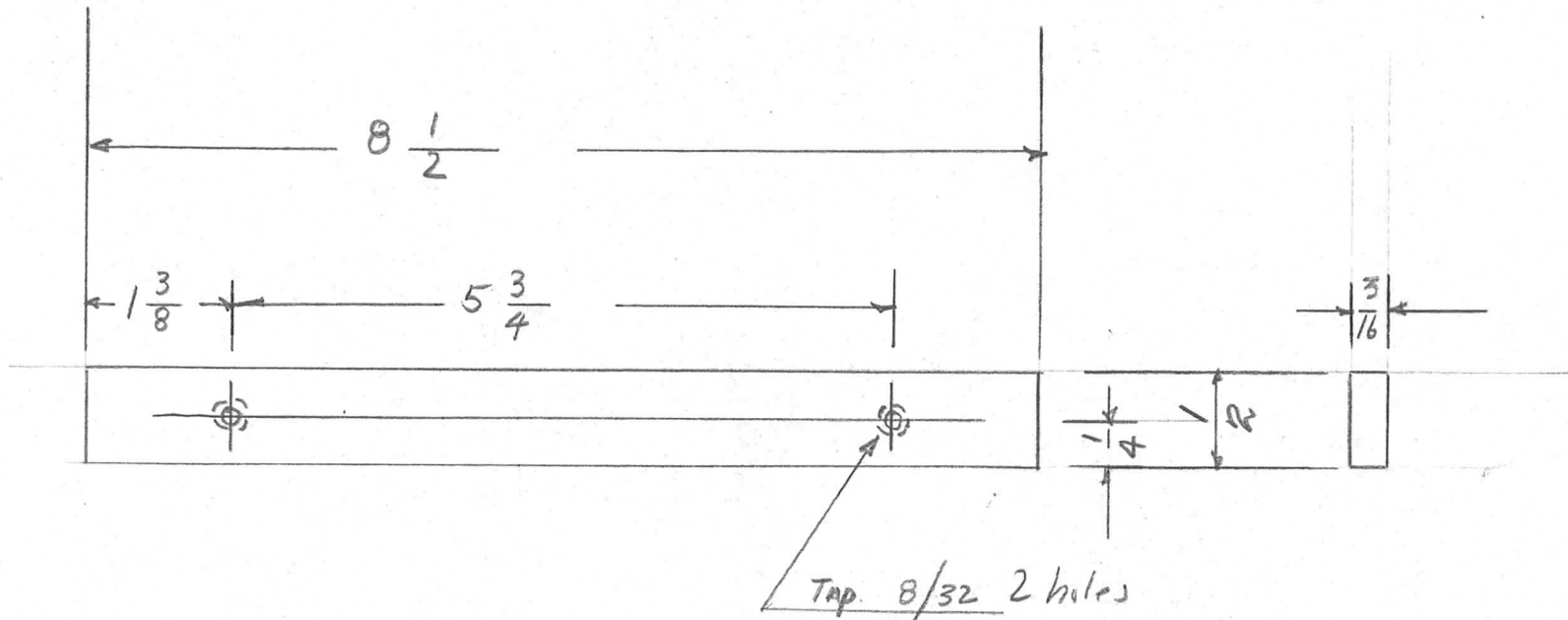

REQ.	ITEM	PART NO.	DESCRIPTION				SYMBOL
		3/16 Thick	THE TECHNICAL MATERIEL CORP.				
		STOCK SIZE	MAMARONECK, NEW YORK				
		BRASS	Panel Bar Nut				
		MATERIAL					
A	2	FINISH DELETED	6/6/57	1	SC.	JNO	ak
	1	MATERIAL WAS ALUM					
ISSUE	ITEM	CHANGED FROM	DATE	CH. NO.	DRAFTS	CHECKER	ENG. APP.
TOLERANCES			SCALE:				
DEC. DIM. \pm	FRAC. DIM. \pm	ANGULAR DIM. \pm	MAXIMUM ALLOWABLE TOLERANCES HAVE BEEN DETERMINED AND ANY DEVIATIONS WILL BE CAUSE FOR REJECTION. REMOVE ALL BURRS AND SHARP EDGES				
		HALF HARD					ak
		TYPE & TEMPER	HEAT TREAT. SPEC.	DRAWN	CHECKED	FINAL APPROVAL	
		Cadmium Plate	.0002			ak	
		FINISH & SPEC. NO.	ELEC. DES. APP.	MECH. DES. APP.	PM-443 A		