

REQ. PER UNIT	USED ON			PM-435
	MODEL	ASS'Y. NO.	DATE	
8	TER-5000	A-1431(8)	3-25-57	

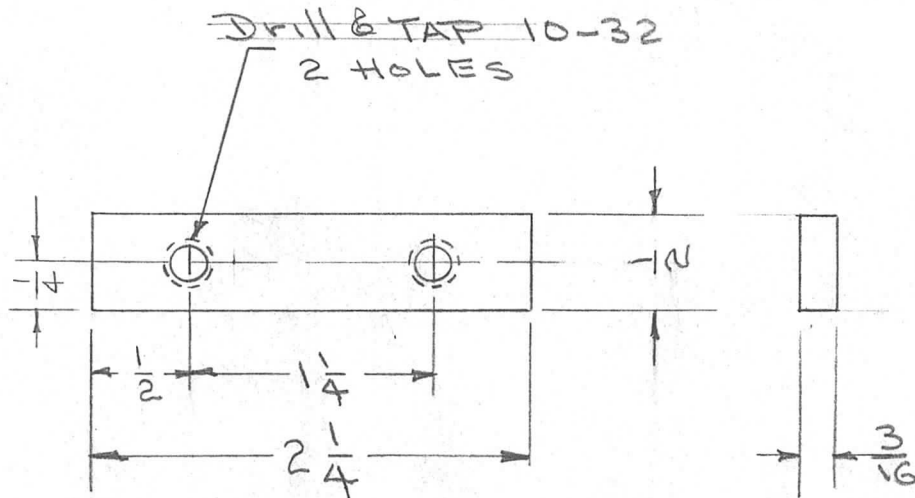

ISSUE	ITEM	CHANGED FROM	DATE	CH. NO.	DRAFTS	CHECKER	ENG. APP.	REQ. ITEM	PART NO.	DESCRIPTION	SYMBOL
									3/16 x 1/2 Rectangular ROD STOCK SIZE	THE TECHNICAL MATERIEL CORP. MAMARONECK, NEW YORK	
									ALUMINUM	NUT, BAR	
									MATERIAL		
									G063-T5	3/25/57	3/25/57
									TYPE & TEMPER	HEAT TREAT. SPEC.	DRAWN
									S-101 Caustic Dip S-107 LACOVER		
									FINISH & SPEC. NO.	ELEC. DES. APP.	MECH. DES. APP.
											PM-435

DEC. DIM. ±  
FRAC. DIM. ± V64  
ANGULAR DIM. ±

SCALE: //  
MAXIMUM ALLOWABLE TOLERANCES HAVE BEEN DETERMINED AND ANY DEVIATIONS WILL BE CAUSE FOR REJECTION.  
REMOVE ALL BURRS AND SHARP EDGES

3/25/57  
DRAWN  
S-101 Caustic Dip  
S-107 LACOVER  
FINISH & SPEC. NO.

3/25/57  
CHECKED  
ELEC. DES. APP. MECH. DES. APP.

PM-435