

REQ. PER UNIT	USED ON			PM-400	A
	MODEL	ASS'Y. NO.	DATE		
1	RTF	A-1273	2-3-56		

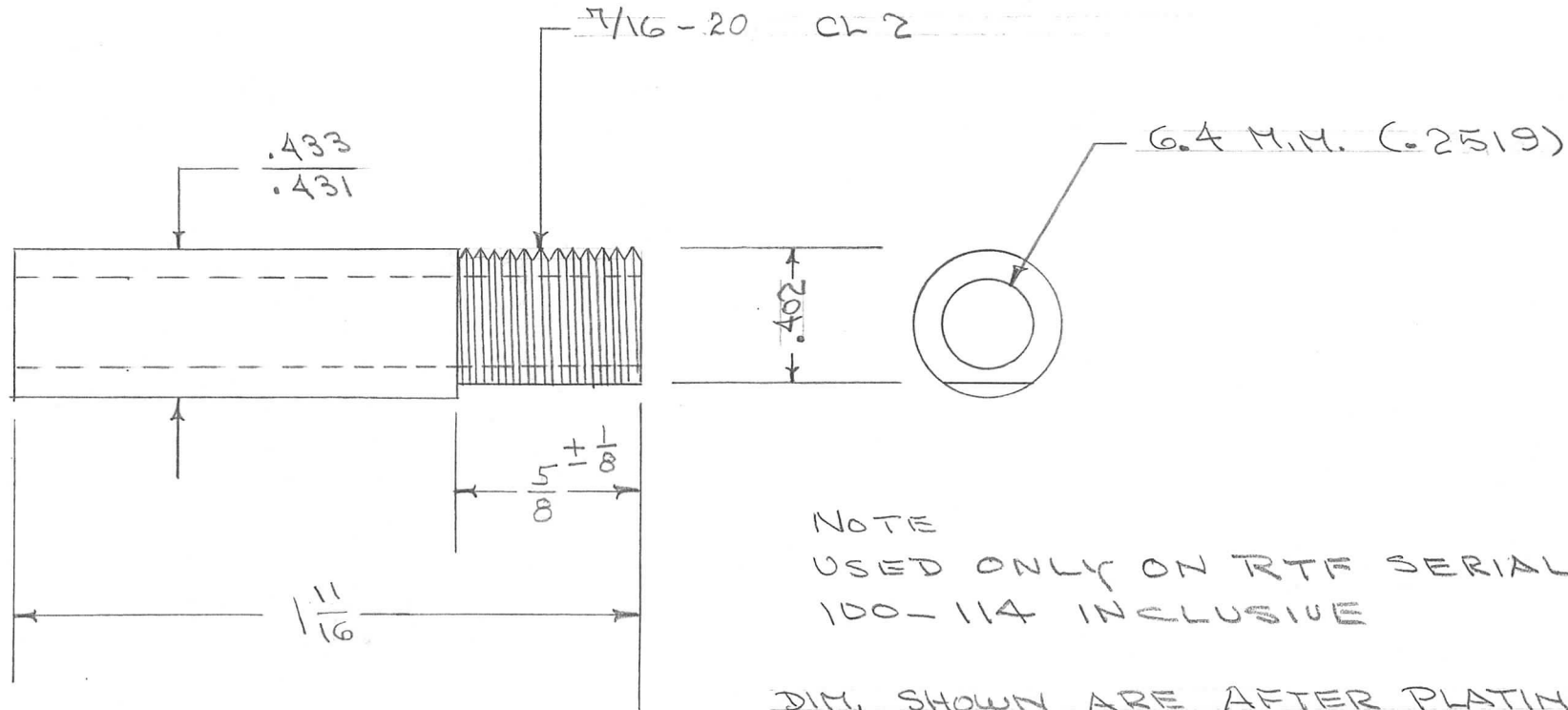

NOTE
USED ONLY ON RTF SERIAL NOS
100-114 INCLUSIVE

DIM. SHOWN ARE AFTER PLATING.

REF: NT-116

REQ. ITEM	PART NO.	DESCRIPTION	SYMBOL							
	7/16 DIA	THE TECHNICAL MATERIEL CORP. MAMARONECK, NEW YORK								
	STOCK SIZE									
A. 1	BRASS	SHAFT, CAP. INCREASE SWITCH Pow/AMP.								
ISSUE ITEM	CHANGED FROM	DATE	CH. NO.	DRAFTS	CHECKER	ENG. APP.	MATERIAL			
	7/16-32 To 7/16-20 1/2 To 5/8 ± 1/8	1/15/56	1	PB	JAW	WDE	FREE TURNING	ADD 2/3/56	JAW	WDE
TOLERANCES		SCALE:		TYPE & TEMPER		HEAT TREAT. SPEC.	DRAWN	CHECKED	FINAL APPROVAL	
DEC. DIM. ±		MAXIMUM ALLOWABLE TOLERANCES HAVE BEEN DETERMINED AND ANY DEVIATIONS WILL BE CAUSE FOR REJECTION.		S-105 CAD PLATE		1,0002		AM 2/6/56	PM-400 A	
FRAC. DIM. ± 1/64		REMOVE ALL BURRS AND SHARP EDGES		FINISH & SPEC. NO.			ELEC. DES. APP.	MECH. DES. APP.		
ANGULAR DIM. ±										