

REQ. PER UNIT	USED ON			PM-382	A
	MODEL	ASS'Y. NO.	DATE		
1	JJ-134	-			
1	JJ-237		12-26-61		

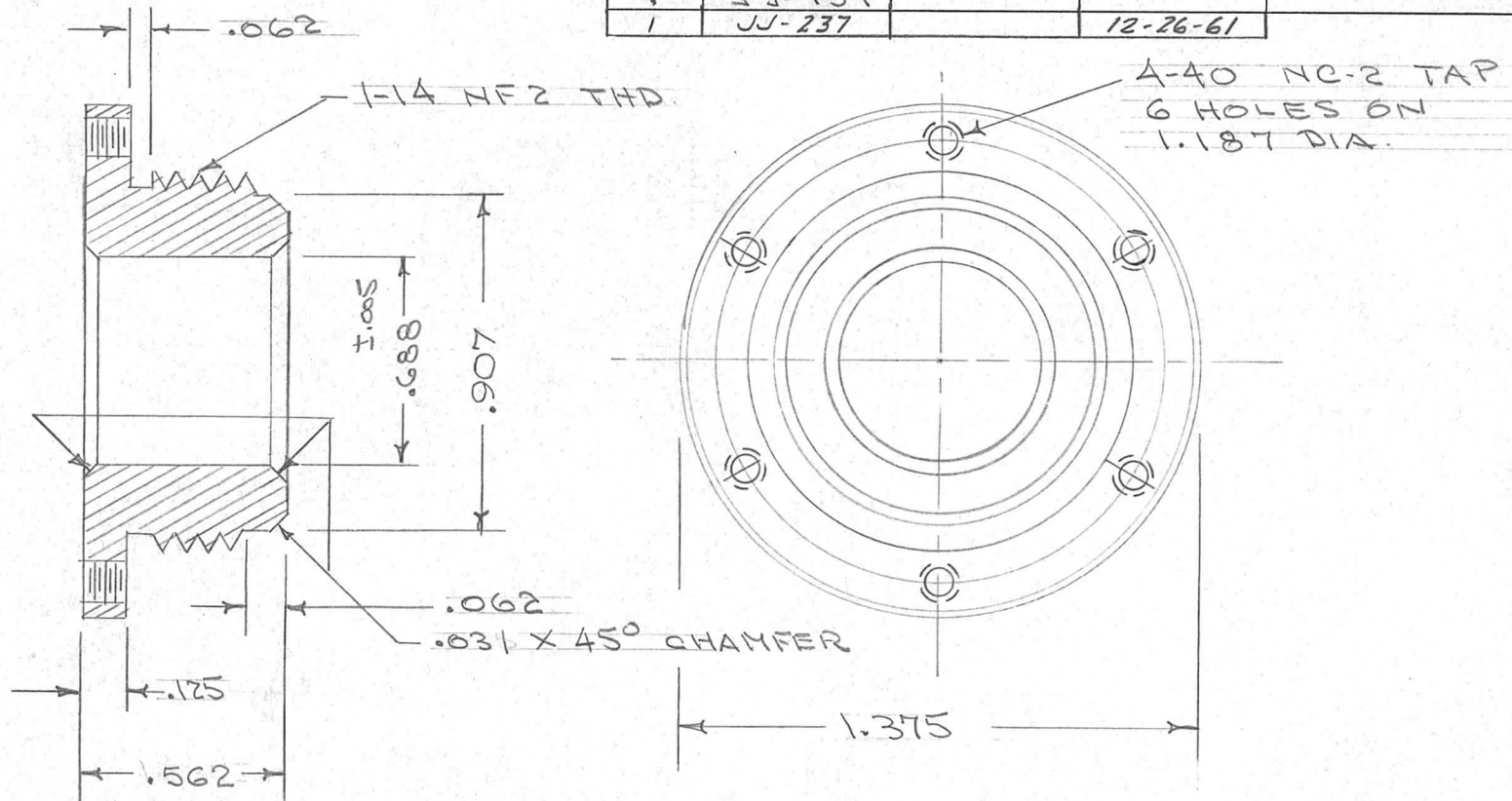

MATERIAL SPEC.: FED. SPEC. 00-B-626, COMP. 22, HALF HARD  
 PART TO BE SILVER PLATED .0002 MIN., PLATING TO BE DENSE, NON POROUS & OF SMALL GRAIN.  
 DIM. SHOWN ARE AFTER PLATING, PART TO BE FREE FROM BURRS & CHIPS.

REQ.	ITEM	PART NO.	DESCRIPTION				SYMBOL
			THE TECHNICAL MATERIEL CORP. MAMARONECK, NEW YORK				
			FLANGE				
A	1	.907 DIM. WAS .937	2-15-62	6365	JJ	<del>SS</del>	chb
ISSUE	ITEM	CHANGED FROM	DATE	CH. NO.	DRAFTS	CHECKER	ENG. APP.
TOLERANCES			SCALE:				
DEC. DIM. ± .015			MAXIMUM ALLOWABLE TOLERANCES HAVE BEEN DETERMINED AND ANY DEVIATIONS WILL BE CAUSE FOR REJECTION.				
FRAC. DIM. ±			REMOVE ALL BURRS AND SHARP EDGES				
ANGULAR DIM. ± 1/2°							
		1/2 HARD	CDD.		HQA		
		TYPE & TEMPER	HEAT TREAT. SPEC.		DRAWN		
		SILVER PLATED			CHECKED		
		.0002			FINAL APPROVAL		
		FINISH & SPEC. NO.	ELEC. DES. APP.		MECH. DES. APP.		
					PM-382		
					A		