

REQ. PER UNIT	USED ON			PM-370	A
	MODEL	ASS'Y. NO.	DATE		
2	RTF		11/22/55		
2	RTF-2	1/C	11/22/58		

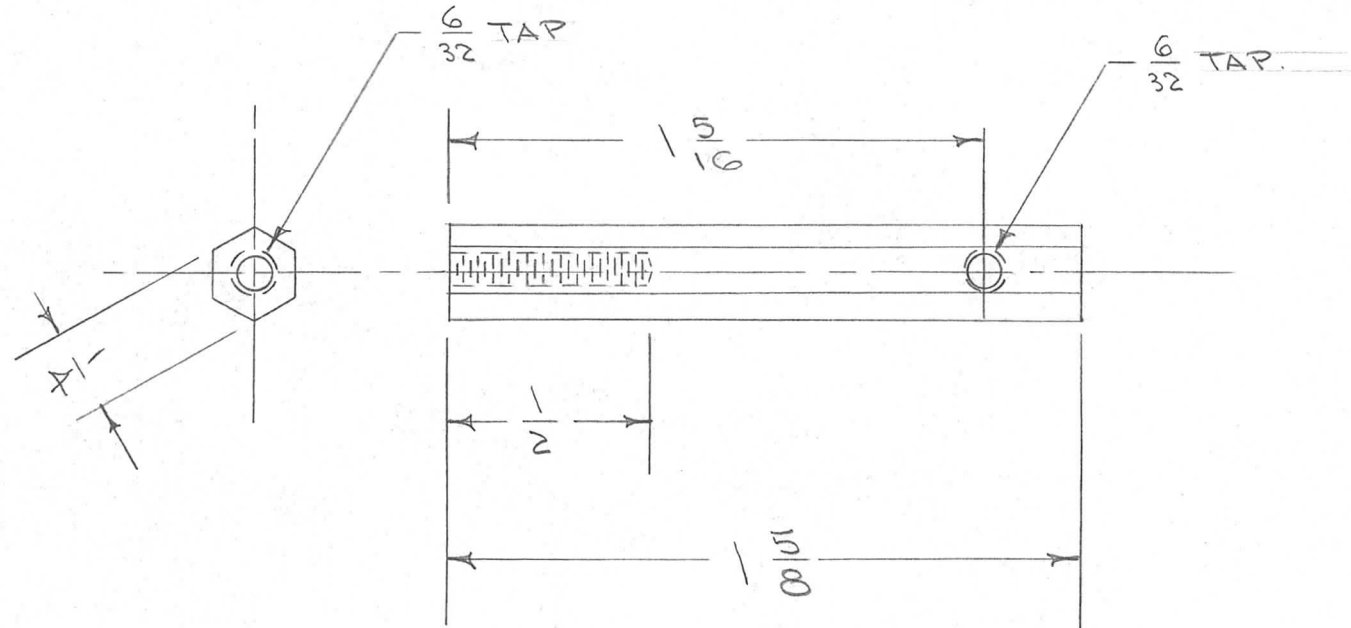

ISSUE	ITEM	CHANGED FROM	DATE	CH. NO.	DRAFTS	CHECKER	ENG. APP.	REQ. ITEM	PART NO.	DESCRIPTION	SYMBOL		
								1/4	HEX ROD.	THE TECHNICAL MATERIEL CORP. MAMARONECK, NEW YORK			
									STOCK SIZE				
A	1	1 5/16 WAS 1 3/8	3/27/56	1	13	John	WJ		ALUMINUM	BRACKET, INTER CONNECT			
									MATERIAL	TERM. BD. 1/C GPT-750			
								175	STA 4	ASD 11/22/55	A. J. J.		
									TYPE & TEMPER	DRAWN	CHECKED	FINAL APPROVAL	
									HEAT TREAT. SPEC.	WJ 12/23/55	WJ	PM-370	A
									FINISH & SPEC. NO.	ELEC. DES. APP.	MECH. DES. APP.		
									S-101 CAUSTIC DIP				

DEC. DIM. ±  
 FRAC. DIM. ± 1/64  
 ANGULAR DIM. ±

SCALE:  
 MAXIMUM ALLOWABLE TOLERANCES HAVE BEEN DETERMINED AND ANY DEVIATIONS WILL BE CAUSE FOR REJECTION.  
 REMOVE ALL BURRS AND SHARP EDGES