

IF IT IS FOUND DESIRABLE TO CHANGE ANY TOLERANCE OR OTHER DETAIL SPECIFIED ON THIS DRAWING NOTIFY THE PURCHASER PROMPTLY.

PM-353

MAXIMUM ALLOWABLE TOLERANCES HAVE BEEN DETERMINED AND DEVIATIONS WILL BE CAUSE FOR REJECTION. REMOVE ALL BURRS AND SHARP EDGES

REQ. PER UNIT	USED ON			
	MODEL	PROJECT NO.	ASS'Y. NO.	DATE
1	FSS			8-2-55

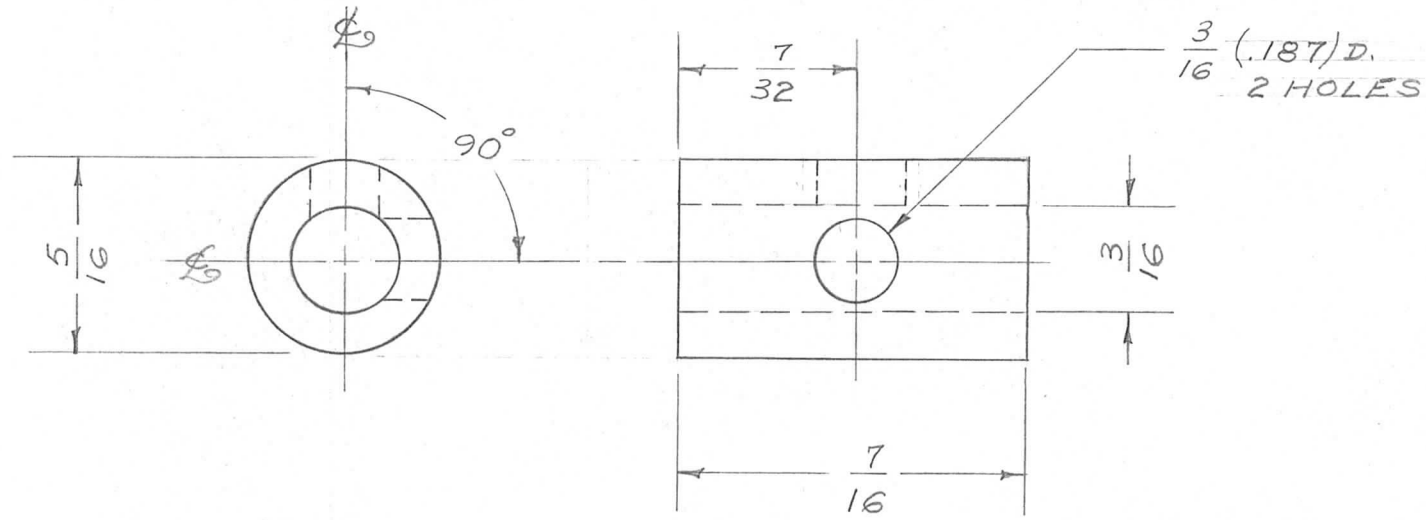

REQ.	ITEM	PART NO.	DESCRIPTION	SYMBOL
	5 D 16	ROD	THE TECHNICAL MATERIEL CORP. MAMARONECK. NEW YORK	
	STOCK SIZE			
	BRASS	#	BUSHING, KNOB	
	MATERIAL	WEIGHT PER PC.	FSS	
	FREE TURNING			
	TYPE & TEMPER		AB 8-2-55	
			DRAWN	ELEC. DES. APP. MECH. DES. APP.
			8-2-55	KZ
	HEAT TREAT. SPEC.		CHECKED	FINAL APPROVAL
				PM-353
	FINISH & SPEC. NO.			

ISSUE	ITEM	CHANGED FROM	DATE	CN. NO.	DRAFTS	CHECKER	ENG. APP.
ALL OTHERS		DEC. DIM. $\pm$ FRAC. DIM. $\pm$ $\frac{1}{64}$ ANGULAR DIM. $\pm$					

SCALE  
DRILL, PUNCH, COMMERCIAL STOCK SIZES AND MANUFACTURERS TOLERANCES ARE NOT INCLUDED.