

IF IT IS FOUND DESIRABLE TO CHANGE ANY TOLERANCE OR OTHER DETAIL SPECIFIED ON THIS DRAWING NOTIFY THE PURCHASER PROMPTLY.

PM-316 E

MAXIMUM ALLOWABLE TOLERANCES HAVE BEEN DETERMINED AND DEVIATIONS WILL BE CAUSE FOR REJECTION. REMOVE ALL BURRS AND SHARP EDGES

REQ. PER UNIT	USED ON			
	MODEL	PROJECT NO.	ASS'Y. NO.	DATE
2	PM0-1	285		8-27-54
2	PM0-2	285		8-27-54
3	VOX-1,2	291		1-12-55
4	RTF	271		2-1-56
2	GSB-1	459		9-21-56
4	RTF-2	F/P		11-20-58
2	RFB-1	GPT-10K		1-20-59
2	RFD-1	PAL-1K		6-22-59

DRILL & TAP 6-32 2 REQ.

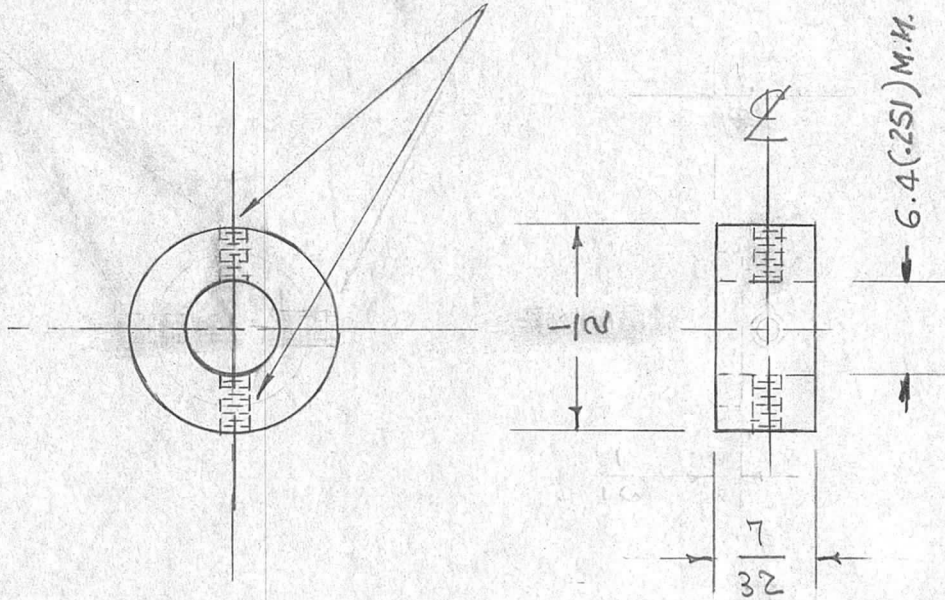

NOTE:  
DIMENSIONS SHOWN ARE AFTER PLATING

ISSUE	ITEM	CHANGED FROM	DATE	CN. NO.	DRAFTS	CHECKER	ENG. APP.
E	1	7/32 WAS 1/4	9/14/56	5	COO	JAL	WJ
D	1	HOLES WERE 90° APART	3/20/56	4	B	JAL	WJ
C	1	RTF WAS 3 REQ	2/15/56	3	JAL	WJ	WJ
B	2	6-32 WAS 1 PER UNIT	3/28/56	2	PP	JAL	WJ
A	1	6.4 MM WAS 252/253	10/21/54	1	JAL	WJ	WJ

REQ.	ITEM	PART NO.	DESCRIPTION	SYMBOL
		1/2 D	THE TECHNICAL MATERIEL CORP. MAMARONECK. NEW YORK	
		STOCK SIZE		
		BRASS	COLLAR	
		MATERIAL	FREE TURNING	
		WEIGHT PER PC.		
		TYPE & TEMPER	ADD. 8-27-54	
		HEAT TREAT. SPEC.		
		FINISH & SPEC. NO.		
TOLERANCES			SCALE	
DEC. DIM. ±			DRILL, PUNCH, COMMERCIAL STOCK	
FRAC. DIM. ± 1/64			SIZES AND MANUFACTURERS	
ANGULAR DIM. ±			TOLERANCES ARE NOT INCLUDED.	
ALL OTHERS			TOLERANCES ARE NOT INCLUDED.	
DRAWN			ELEC. DES. APP.	
CHECKED			MECH. DES. APP.	
FINAL APPROVAL				
PM-316			E	