

IF IT IS FOUND DESIRABLE TO CHANGE ANY TOLERANCE OR OTHER DETAIL SPECIFIED ON THIS DRAWING NOTIFY THE PURCHASER PROMPTLY.

PM-313

MAXIMUM ALLOWABLE TOLERANCES HAVE BEEN DETERMINED AND DEVIATIONS WILL BE CAUSE FOR REJECTION. REMOVE ALL BURRS AND SHARP EDGES

REQ
PER
UNIT

USED ON

MODEL

PROJECT NO.

ASS'Y. NO.

DATE

1

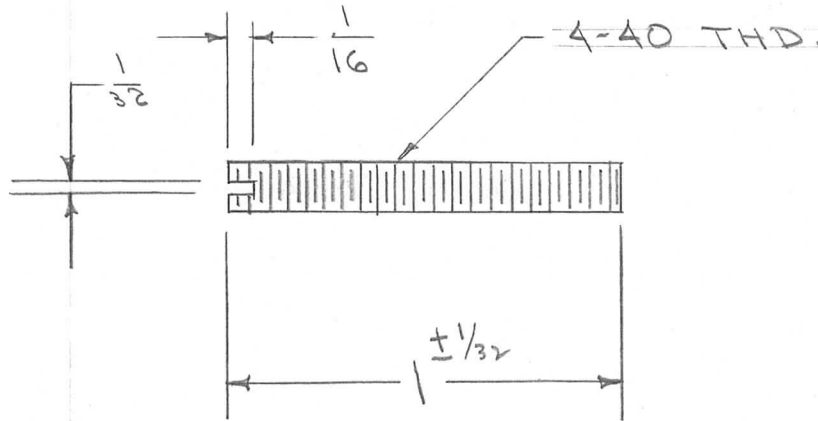

REQ.	ITEM	PART NO.	DESCRIPTION	SYMBOL
			THE TECHNICAL MATERIEL CORP. MAMARONECK. NEW YORK	
		THREADED ROD		
		STOCK SIZE		
		STAINLESS STEEL	PIN, CALIBRATE CONTROL	
		MATERIAL	P.M.O	
		WEIGHT PER PC.		
		TYPE & TEMPER	C.D.D. 8-25-54	
		HEAT TREAT. SPEC.		
		FINISH & SPEC. NO.	S-104 PASSIVATE	

ISSUE ITEM CHANGED FROM DATE CN. NO. DRAFTS CHECKER ENG. APP.

TOLERANCES

SCALE

DRILL, PUNCH, COMMERCIAL STOCK SIZES AND MANUFACTURERS TOLERANCES ARE NOT INCLUDED.

ALL OTHERS

DEC. DIM. \pm
FRAC. DIM. $\pm \frac{1}{64}$
ANGULAR DIM. \pm

DRAWN

ELEC. DES. APP.

MECH. DES. APP.

CHECKED

FINAL APPROVAL

PM-313