

IF IT IS FOUND DESIRABLE TO CHANGE ANY TOLERANCE OR OTHER DETAIL SPECIFIED ON THIS DRAWING NOTIFY THE PURCHASER PROMPTLY.

PM-274 A

MAXIMUM ALLOWABLE TOLERANCES HAVE BEEN DETERMINED AND DEVIATIONS WILL BE CAUSE FOR REJECTION. REMOVE ALL BURRS AND SHARP EDGES

REQ. PER UNIT	USED ON			
	MODEL	PROJECT NO.	ASS'Y. NO.	DATE
1	TAC-1	132	SW-145	12-21-53

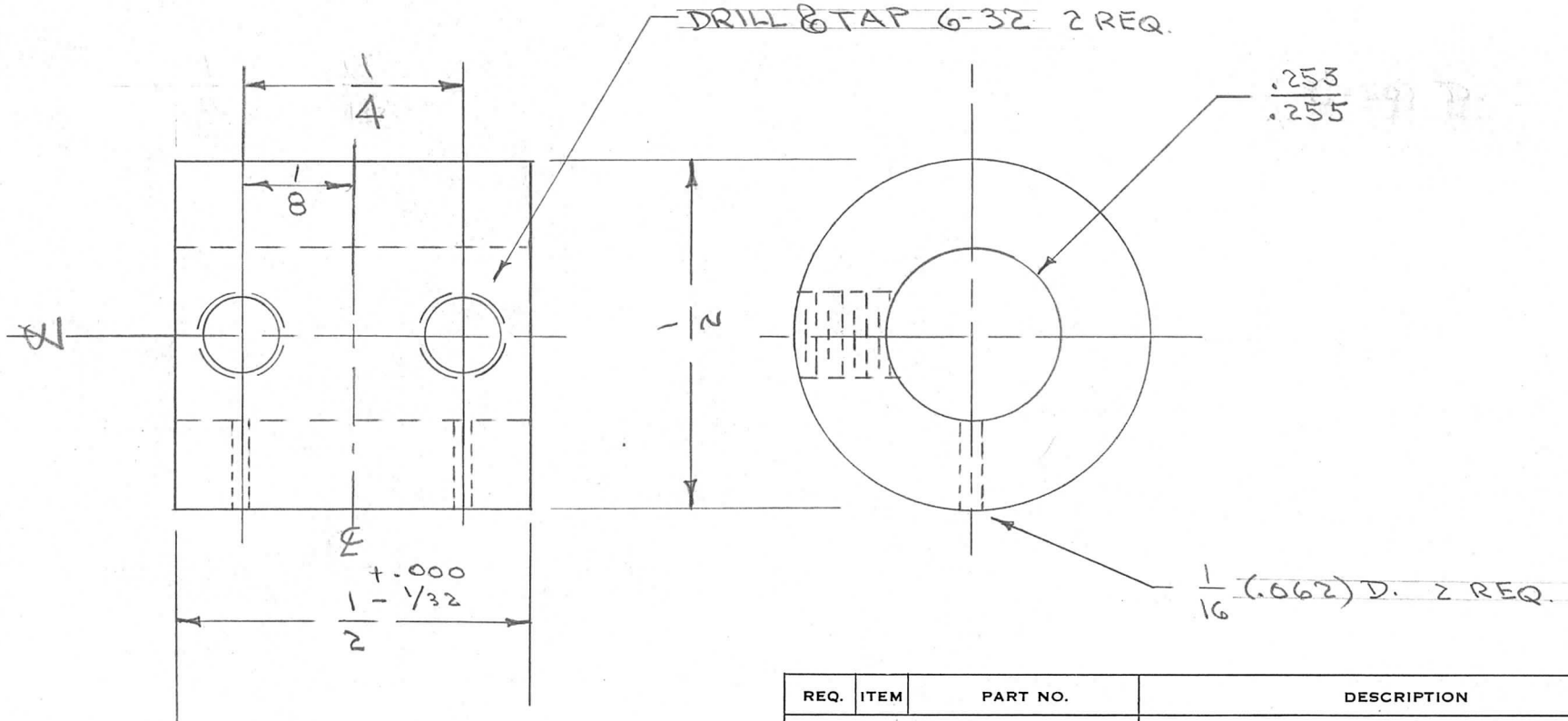

REQ.	ITEM	PART NO.	DESCRIPTION	SYMBOL
		1/2 DIA.	THE TECHNICAL MATERIEL CORP. MAMARONECK, NEW YORK	
		STOCK SIZE		
		BRASS		BUSHING, BAND SWITCH.
		MATERIAL	WEIGHT PER PC.	
		FREE TURNING	TAC-1	
		TYPE & TEMPER	C.I.D.D	
		II	ARB	WSE
		HEAT TREAT. SPEC.	DRAWN	ELEC. DES. APP.
		S-105 CAD. PLATE	WSE	ARB
		FINISH & SPEC. NO.	CHECKED	FINAL APPROVAL
				PM-274 A

ISSUE	ITEM	CHANGED FROM	DATE	CN. NO.	DRAFTS	CHECKER	ENG. APP.
A	1	.253 .255	was .251 .252	4/10/54	1	WSE JAR WSE	WSE
TOLERANCES			SCALE II				
ALL OTHERS	DEC. DIM. ± FRAC. DIM. ± 1/64 ANGULAR DIM. ±		DRILL, PUNCH, COMMERCIAL STOCK SIZES AND MANUFACTURERS TOLERANCES ARE NOT INCLUDED.				