

IF IT IS FOUND DESIRABLE TO CHANGE ANY TOLERANCE OR OTHER DETAIL SPECIFIED ON THIS DRAWING NOTIFY THE PURCHASER PROMPTLY.

PM-240

MAXIMUM ALLOWABLE TOLERANCES HAVE BEEN DETERMINED AND DEVIATIONS WILL BE CAUSE FOR REJECTION. REMOVE ALL BURRS AND SHARP EDGES

RELEASED

USED ON

MODEL	PROJECT NO.	ASS'Y. NO.	DATE
JJ-117		A-479	

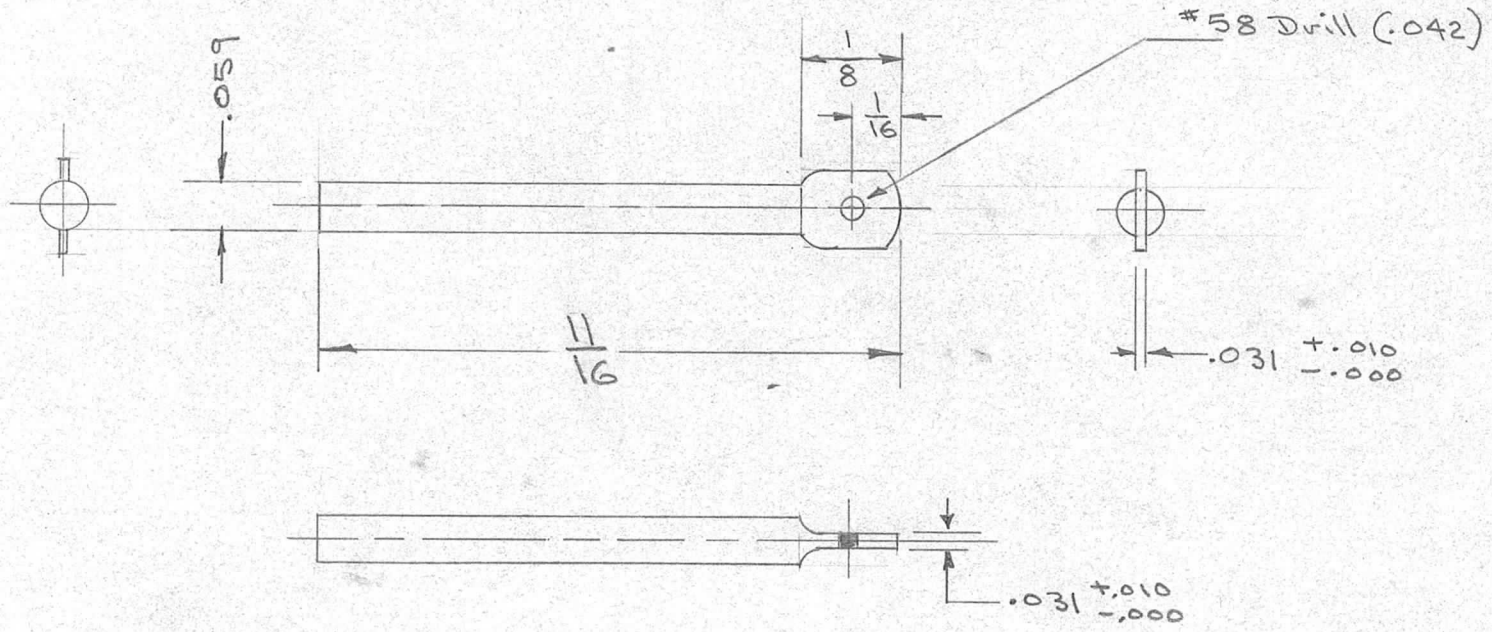

REQ.	ITEM	PART NO.	DESCRIPTION	SYMBOL
		#53 (.059)	THE TECHNICAL MATERIEL CORP. MAMARONECK, NEW YORK	
		STOCK SIZE		
		BRASS ROD	SOLDER PIN	
		MATERIAL		
		WEIGHT PER PC.		
		DRILL GAUGE		
		TYPE & TEMPER		
			JADE 6-11-53 DRAWN	
			WDE 6-12-53	
		HEAT TREAT. SPEC.		
			CHECKED	FINAL APPROVAL
		FINISH & SPEC. NO.		PM-240

ISSUE	ITEM	CHANGED FROM	DATE	CN. NO.	DRAFTS	CHECKER	ENG. APP.
TOLERANCES			SCALE				
ALL OTHERS	DEC. DIM. \pm FRAC. DIM. \pm $\frac{1}{64}$ ANGULAR DIM. \pm		DRILL, PUNCH, COMMERCIAL STOCK SIZES AND MANUFACTURERS TOLERANCES ARE NOT INCLUDED.				