

IF IT IS FOUND DESIRABLE TO CHANGE ANY TOLERANCE OR OTHER DETAIL SPECIFIED ON THIS DRAWING NOTIFY THE PURCHASER PROMPTLY.

PM-215 B

MAXIMUM ALLOWABLE TOLERANCES HAVE BEEN DETERMINED AND DEVIATIONS WILL BE CAUSE FOR REJECTION. REMOVE ALL BURRS AND SHARP EDGES

REQ. PER. UNIT

USED ON

MODEL

PROJECT NO.

ASS'Y. NO.

DATE

1

A-1000

A-422

LIGHT PRESS FIT FOR INNER BORE ON NEW DEPARTURE BEARING # R-4 (BB-105)

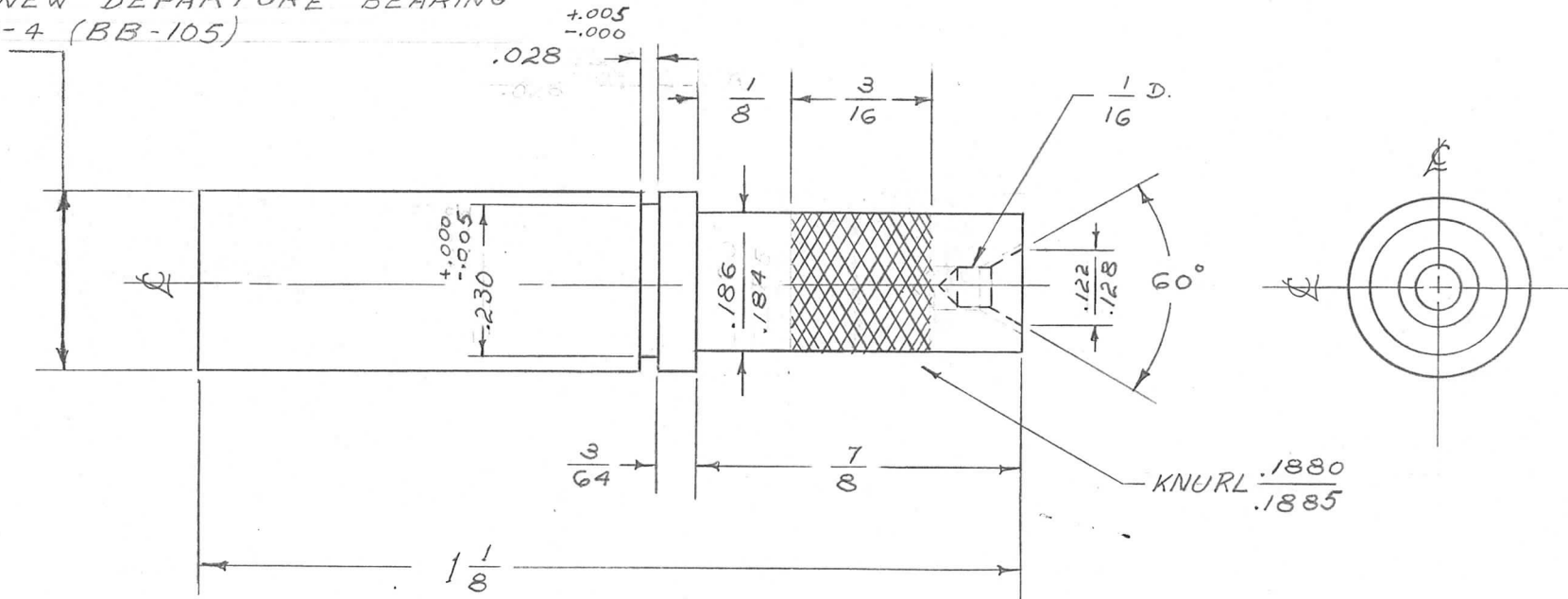

REQ.	ITEM	PART NO.	DESCRIPTION	SYMBOL
		— # —	THE TECHNICAL MATERIEL CORP.	
		STOCK SIZE	MAMARONECK. NEW YORK	
		STEEL — # —	PINION SHAFT	
		MATERIAL WEIGHT PER PC.		
		STAINLESS		
		TYPE & TEMPER	P.B. 12-17-54	
		NO. 303	DRAWN	ELEC. DES. APP. MECH. DES. APP.
		HEAT TREAT. SPEC.	Checked	Final Approval
		FINISH & SPEC. NO.		PM-215 B

ISSUE	ITEM	CHANGED FROM	DATE	CN. NO.	DRAFTS	CHECKER	ENG. APP.
B	1	REVISED, REDRAWN	12-17-54	2	R.B.	JAW	WDC
TOLERANCES			SCALE A SIZE				
ALL OTHERS	DEC. DIM. ± FRAC. DIM. ± 1/64 ANGULAR DIM. ±		DRILL, PUNCH, COMMERCIAL STOCK SIZES AND MANUFACTURERS TOLERANCES ARE NOT INCLUDED.				