

APPLICATION				REVISIONS						
QTY	MODEL USED ON	ASS'Y NO.	LTR	DESCRIPTION	DATE	E.M.N.NO	DRAFT	CHKD	APPD	
1	HFTA-10K	AX 521B	Ø	ORIGINAL RELEASE	9-22-80	<i>m</i>	<i>dw</i>			

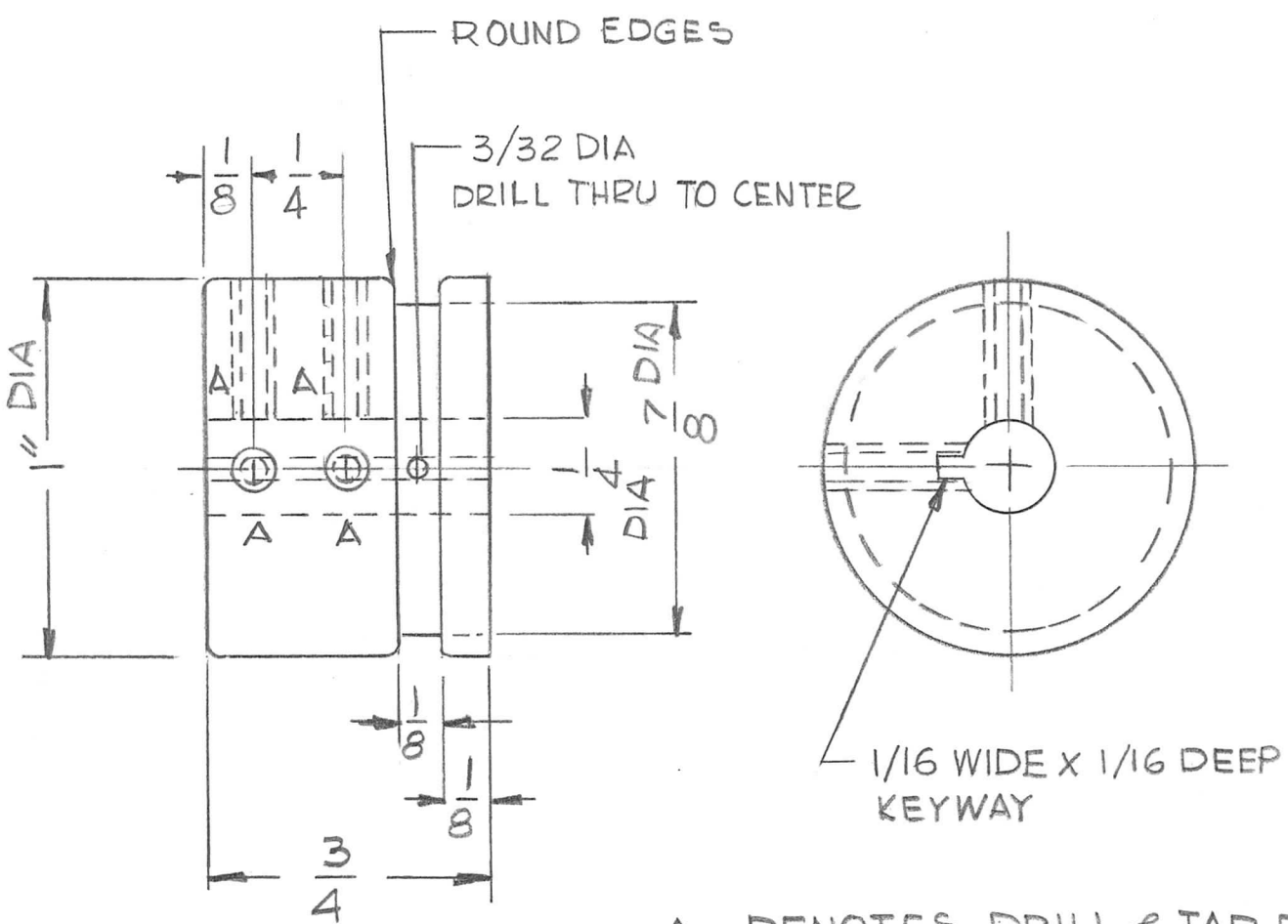

A- DENOTES DRILL & TAP FOR .0632 THD. TO CENTER (4REQ)

UNLESS OTHERWISE SPECIFIED DIMENSIONS ARE IN INCHES AND INCLUDE CHEMICALLY APPLIED OR PLATED FINISHES		REQ'D	ITEM	PART NUMBER	DESCRIPTION	SYM.
LIST OF MATERIAL						
DECIMALS: .X ± .05, .XX ± .01, .XXX ± .005 FRACTIONS: 1/64 TOLS.: ANGLES 0°-30°		FINAL APPROVAL <i>OXB</i>		DATE	<b>THE TECHNICAL MATERIEL CORP.</b> MAMARONECK, NEW YORK  <b>PULLEY</b>	
MATERIAL <b>BRASS</b>		MECH. DES.		DATE		
FINISH		ELECT. DES.		DATE		
		CHECKED		DATE		
		DRAWN <i>G.D.L.</i>		DATE <i>1-17-77</i>		

NOTICE TO PERSONS RECEIVING THIS DRAWING THE TECHNICAL MATERIEL CORPORATION claims proprietary right in the material disclosed hereon. This drawing is issued in confidence for engineering information only and may not be reproduced or used to manufacture anything shown hereon without permission from THE TECHNICAL MATERIEL CORPORATION to the user. This drawing is loaned for mutual assistance and is subject to recall at any time.				SIZE <b>A</b>	CODE IDENT. NO. <b>82679</b>	DWG NO. <b>PM 1592</b>	ISSUE <i>Ø</i>
SCALE		SHEET		OF			