

REVISIONS							
E.M.N. NO.	DRAFT	CHKD	ZONE	LTR	DESCRIPTION	DATE	APPROVED
	G.D.L.			X1	DIMS. 2-13/16 WAS 27/16, 1-1/4 WAS 7/8	4-24-74	
				X2	PIN LOCATION DELETED	7-19-74	
	G.D.L.			X3	ITEM ① ADD.	9-23-75	
	G.D.L.			X4	DIM 2-1/2 WAS 2-13/16	12-14-76	
	G.D.L.			Ø	ORIGINAL RELEASE FOR PRODUCTION	1-25-77	*

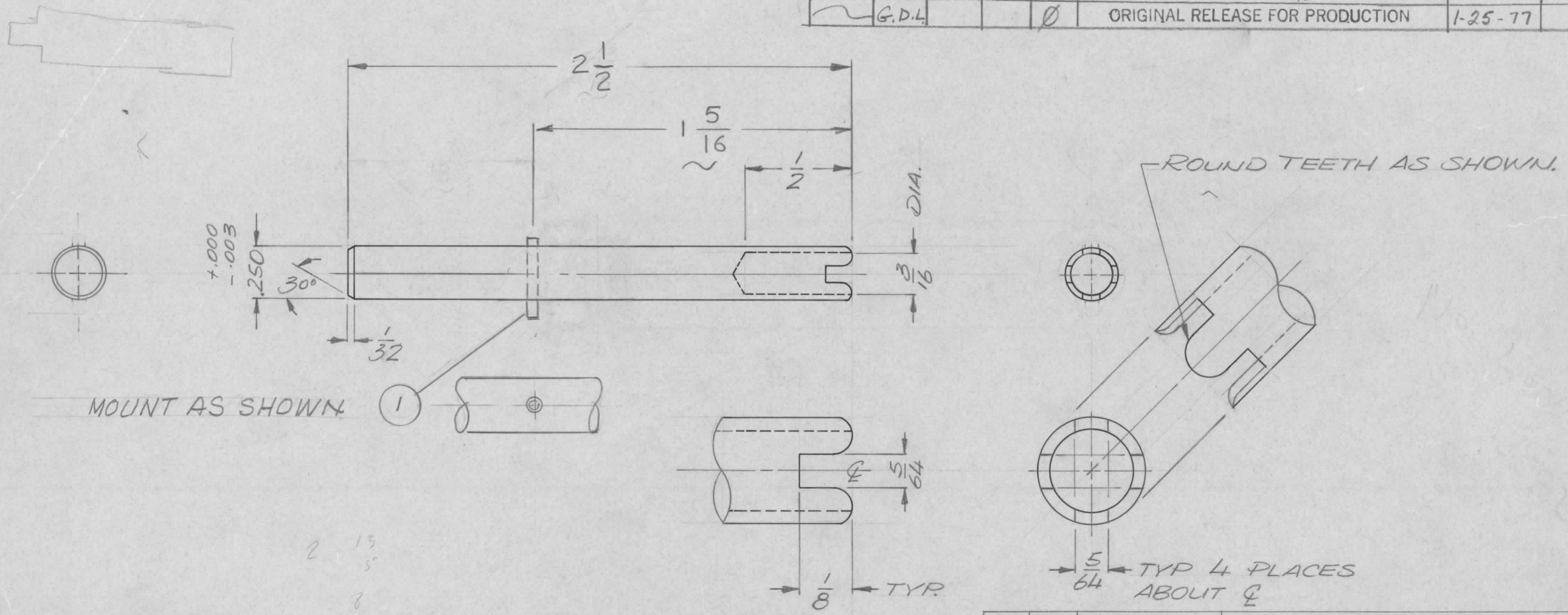

REQ'D	ITEM	PART NUMBER	DESCRIPTION	SYM.
1	1	PN59-0626	PIN SPRING	

LIST OF MATERIAL

1 GPR110 AX5186

QTY / UNIT MODEL USED ON ASS'Y NO.

APPLICATION

CODE

**NOTICE TO PERSONS RECEIVING THIS DRAWING**  
 THE TECHNICAL MATERIEL CORPORATION claims proprietary right in the material disclosed hereon. This drawing is issued in confidence for engineering information only and may not be reproduced or used to manufacture anything shown hereon without permission from THE TECHNICAL MATERIEL CORPORATION to the user. This drawing is loaned for mutual assistance and is subject to recall at any time.

UNLESS OTHERWISE SPECIFIED DIMENSIONS ARE IN INCHES AND INCLUDE CHEMICALLY APPLIED OR PLATED FINISHES

DECIMALS .X ± .05  
 .XX ± .01  
 .XXX ± .005  
 FRACTIONS 1/64  
 TOLS. ANGLES 0° -30'

MATERIAL STAINLESS STEEL

FINISH NATURAL

FINAL APPROVAL *DOB* DATE 1/10/77  
 MECH. DES. DATE  
 ELECT. DES. DATE  
 CHECKED DATE  
 DRAWN *QE* DATE 1/15/74

THE TECHNICAL MATERIEL CORP.  
 MAMARONECK, NEW YORK

SHAFT, SW.

SIZE B CODE IDENT. NO. 82679 DWG NO. PM1574 ISSUE ①

SCALE 2:1 SHEET OF