

QTY	MODEL USED ON	ASS'Y NO.	LTR	DESCRIPTION	DATE	E.M.N.NO	DRAFT	CHKD	APPD
2	HFLA10K	A4819 A4820	Ø	ORIG RELEASE	2/3/72		GE	A.P.	

DRILL & TAP 0832  
3/16 DEEP

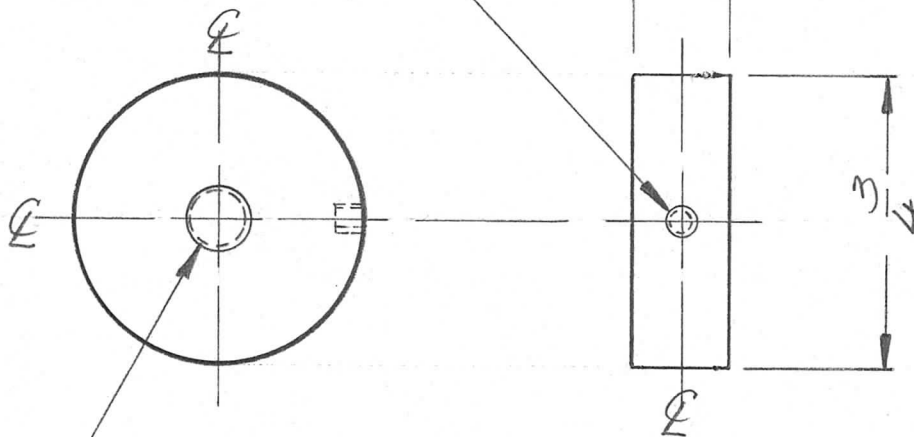

DRILL & TAP 2520 (THRU)

UNLESS OTHERWISE SPECIFIED DIMENSIONS ARE IN INCHES AND INCLUDE CHEMICALLY APPLIED OR PLATED FINISHES

DECIMALS FRACTIONS  
.X ± .05 1/64  
.XX ± .01 TOLS. ANGLES  
.XXX ± .005 0° -30'

MATERIAL BRASS

FINISH NONE

REQ'D	ITEM	PART NUMBER	DESCRIPTION	SYM.
-------	------	-------------	-------------	------

F.B. LIST OF MATERIAL

FINAL APPROVAL *JW* DATE 3 Feb 72

MECH. DES. AL PETROCCA DATE 2-3-72

ELECT. DES. DATE

CHECKED DATE

DRAWN GE DATE 2/3/72

THE TECHNICAL MATERIEL CORP.  
MAMARONECK, NEW YORK  
  
COLLAR, THREADED

NOTICE TO PERSONS RECEIVING THIS DRAWING  
THE TECHNICAL MATERIEL CORPORATION claims proprietary right in the material disclosed hereon. This drawing is issued in confidence for engineering information only and may not be reproduced or used to manufacture anything shown hereon without permission from THE TECHNICAL MATERIEL CORPORATION to the user. This drawing is loaned for mutual assistance and is subject to recall at any time.

SIZE	CODE IDENT. NO.	DWG NO.	ISSUE
A	82679	PM 1516	Ø
SCALE 2:1	SHEET OF		