

QTY	MODEL USED ON	ASS'Y NO.	LTR	DESCRIPTION	DATE	E.M.N.NO	DRAFT	CHKD	APPD
1	AF109	A4808	X ₁	REDESIGNED	9/9/69				J.A.
			Ø	ORIGINAL RELEASE	5/3/73		C.S.		

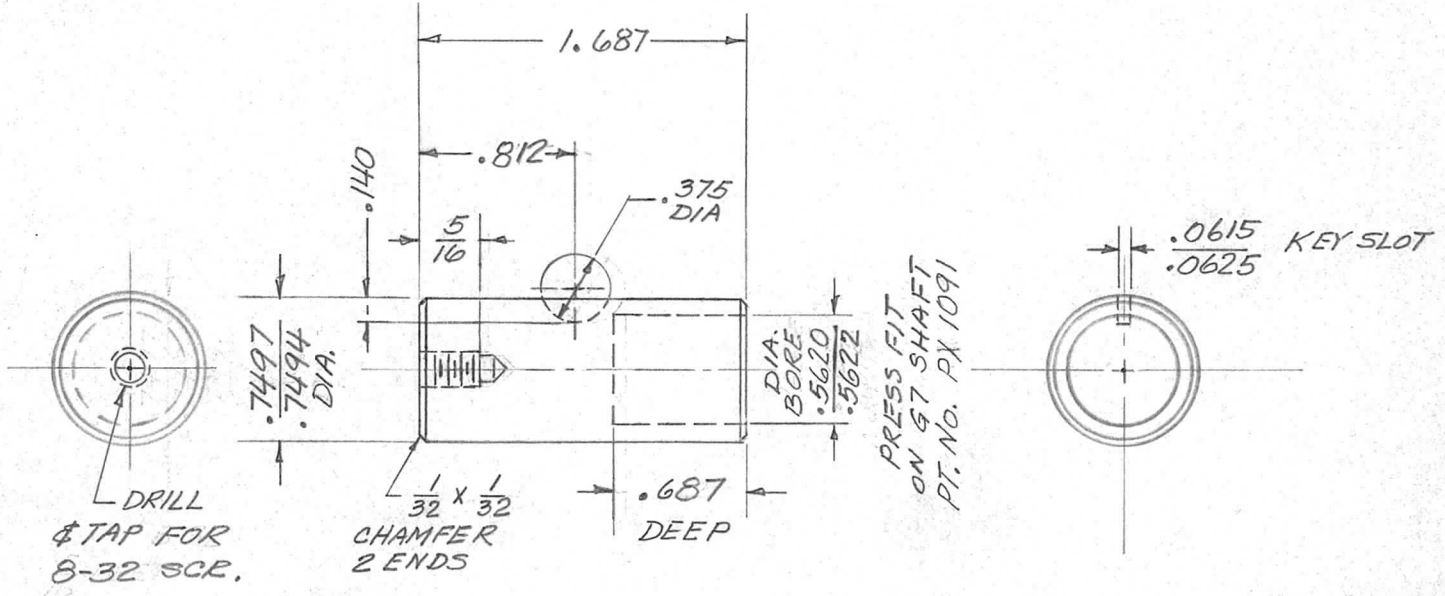

UNLESS OTHERWISE SPECIFIED DIMENSIONS ARE IN INCHES AND INCLUDE CHEMICALLY APPLIED OR PLATED FINISHES		REQ'D	ITEM	PART NUMBER	DESCRIPTION	SYM.
DECIMALS .X ± .05 .XX ± .01 .XXX ± .005 FRACTIONS 1/64 TOLS. ANGLES 0° - 30°		LIST OF MATERIAL				
MATERIAL #303 S. STEEL		FINAL APPROVAL <i>J. ANGER</i>		DATE 9/9/69	THE TECHNICAL MATERIEL CORP. MAMARONECK, NEW YORK <i>HUB, SHAFT</i>	
FINISH PASSIVATE AS PER S104		MECH. DES.		DATE		
		ELECT. DES.		DATE		
		CHECKED		DATE		
		DRAWN <i>J. ANGER</i>		DATE 9/9/69		

NOTICE TO PERSONS RECEIVING THIS DRAWING THE TECHNICAL MATERIEL CORPORATION claims proprietary right in the material disclosed hereon. This drawing is issued in confidence for engineering information only and may not be reproduced or used to manufacture anything shown hereon without permission from THE TECHNICAL MATERIEL CORPORATION to the user. This drawing is loaned for mutual assistance and is subject to recall at any time.				SIZE A	CODE IDENT. NO. 82679	DWG NO. FPM 1425	ISSUE Ø
SCALE 1" = 1"				SHEET 1 OF 1			