

MATERIAL - G7 SILICONE GLASS

DETAIL "A"

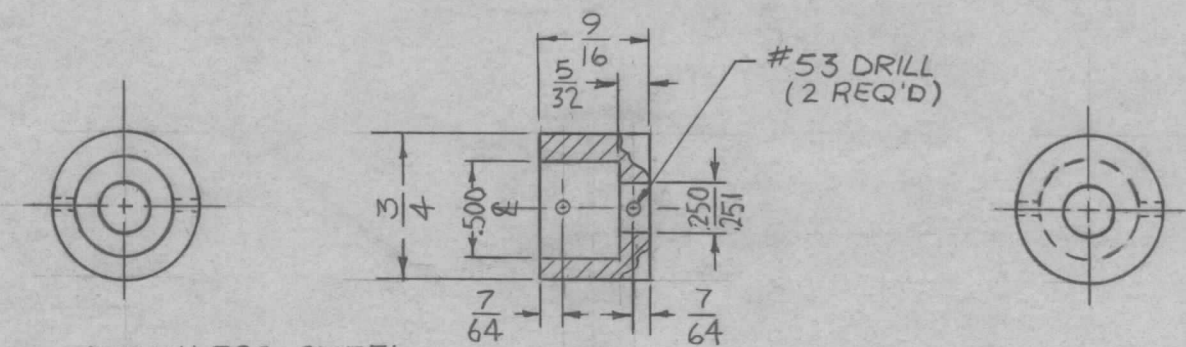

MATERIAL - STAINLESS STEEL 303

DETAIL "B"

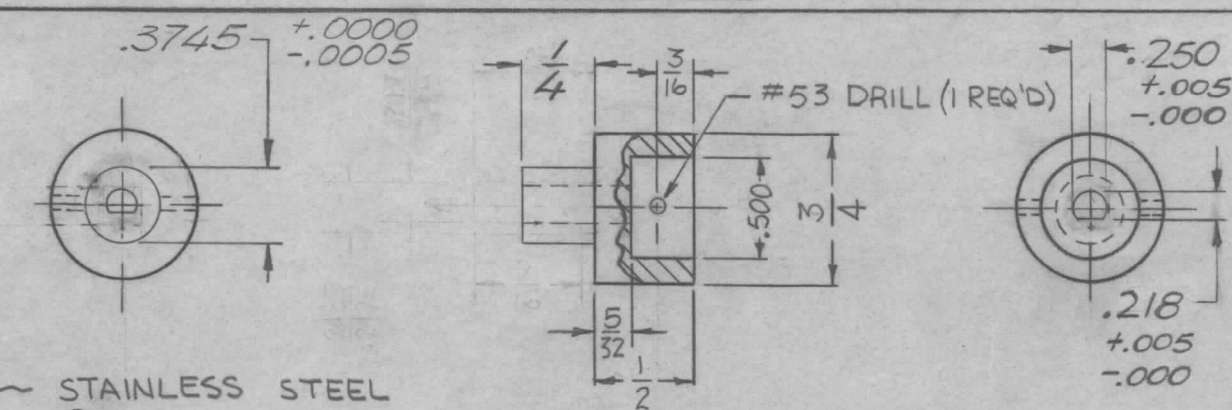

MATERIAL - STAINLESS STEEL 303

DETAIL "C"

REVISIONS							
ZONE	LTR	DESCRIPTION	DATE	E.M.N.NO	DRAFT	CHKD	APPD
	Ø	ORIG. RELEASE	1/27/70		GE		
	A	C'DET. DIM 1/4 WAS 3/8	5/19/70		GE		
	B	OVERALL LEN. CHG WAS 2 3/8	3/21/72	20567	GE	EL	EL

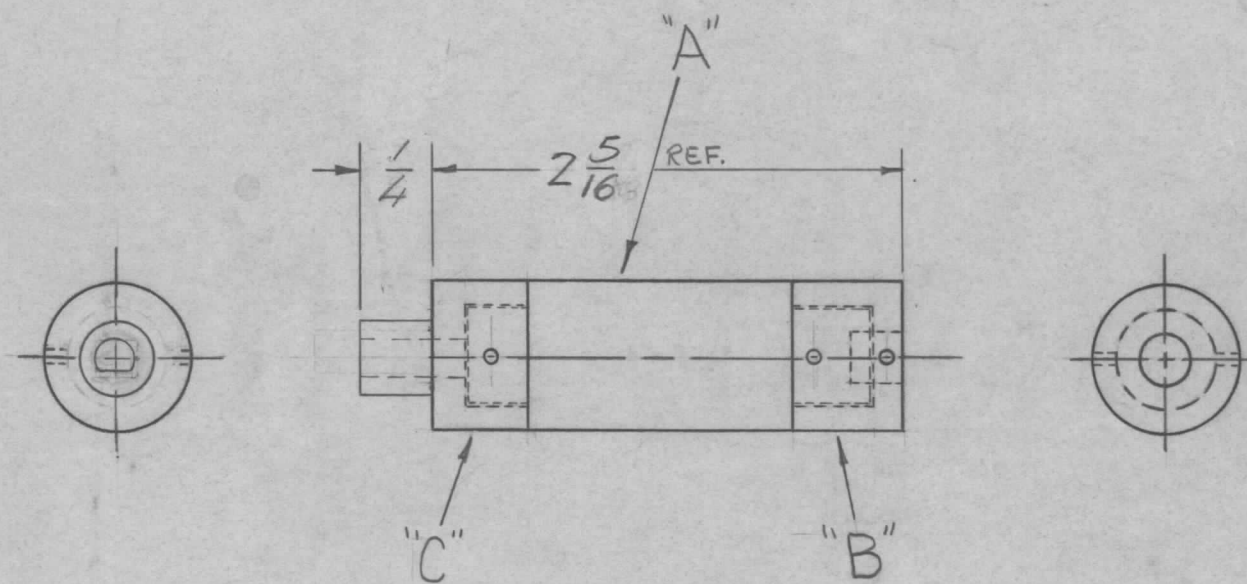

NOTE: ASSEMBLE "A", "B" & "C" WITH ITEM 1, PRESS-FITTING AND PIN WITH ITEM 2.

REQ'D	ITEM	PART NUMBER	DESCRIPTION	SYM.
3	2	PN-59.062-12	PIN SPLINE	
	1	GL 125	ADHESIVE EPOXY	

F. BUDETTI LIST OF MATERIAL

1	HFLA-10K	AX5114
1	PALA-10K	AX5084
QTY / UNIT	MODEL USED ON	ASS'Y NO.
APPLICATION		
CODE		

NOTICE TO PERSONS RECEIVING THIS DRAWING
 THE TECHNICAL MATERIEL CORPORATION claims proprietary right in the material disclosed hereon. This drawing is issued in confidence for engineering information only and may not be reproduced or used to manufacture anything shown hereon without permission from THE TECHNICAL MATERIEL CORPORATION to the user. This drawing is loaned for mutual assistance and is subject to recall at any time.

UNLESS OTHERWISE SPECIFIED DIMENSIONS ARE IN INCHES AND INCLUDE CHEMICALLY APPLIED OR PLATED FINISHES

DECIMALS	FRACTIONS	TOLS.
.X ± .05	1/64	
.XX ± .01	ANGLES	
.XXX ± .005	0° .30'	

MATERIAL
 FINISH

FINAL APPROVAL	DATE
MECH. DES.	DATE
ELECT. DES.	DATE
CHECKED	DATE
DRAWN	DATE

THE TECHNICAL MATERIEL CORP.
 MAMARONECK, NEW YORK

SHAFT, CAPACITOR

SIZE	CODE IDENT. NO.	DWG NO.	ISSUE
B	82679	PM 1417	B

SCALE NTS SHEET OF