

APPLICATION			REVISIONS						
QTY	MODEL USED ON	ASS'Y NO.	LTR	DESCRIPTION	DATE	E.M.N.NO	DRAFT	CHKD	APPD
4	PALA 10K	AX5114	X	EXP RELEASE	4/29/70		GE		
			Ø	ORIG RELEASE FOR PROD	6/18/70		CV		
			A	ADD S404-FINISH	6/15/72	20732	GE	EJ	Ø

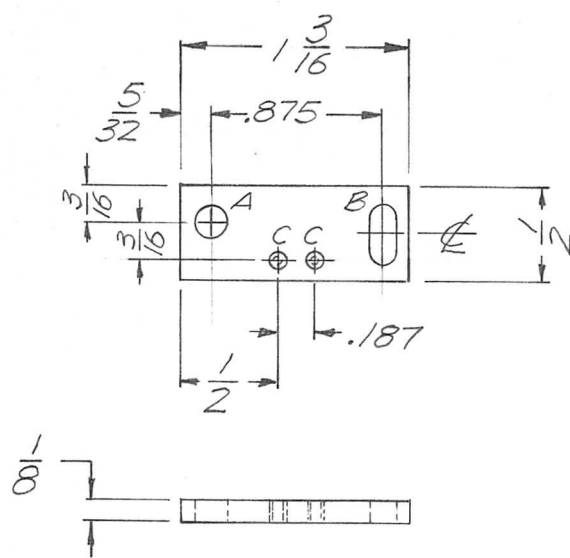

HOLE	DESCRIPTION	QTY.
A	5/32 DIA.	1
B	1/8 X 5/16 SLT.	1
C	DRILL & TAP FOR 2-56 THD.	2

UNLESS OTHERWISE SPECIFIED DIMENSIONS ARE IN INCHES AND INCLUDE CHEMICALLY APPLIED OR PLATED FINISHES

DECIMALS: .X ± .05, .XX ± .01, .XXX ± .005
 FRACTIONS: 1/64
 TOLS. ANGLES: 0° -30'

REQ'D	ITEM	PART NUMBER	DESCRIPTION	SYM.
F. BUDETTI LIST OF MATERIAL				
FINAL APPROVAL		DATE	THE TECHNICAL MATERIEL CORP. MAMARONECK, NEW YORK <i>MTG. PLATE, SWITCH</i>	
MECH. DES.		DATE		
ELECT. DES.		DATE		
CHECKED		DATE		
DRAWN		DATE		

MATERIAL 1/8 ALUM

FINISH S404 YEL. IRIDITE

DRAWN EVANGELIST DATE 4-29-70

NOTICE TO PERSONS RECEIVING THIS DRAWING
 THE TECHNICAL MATERIEL CORPORATION claims proprietary right in the material disclosed hereon. This drawing is issued in confidence for engineering information only and may not be reproduced or used to manufacture anything shown hereon without permission from THE TECHNICAL MATERIEL CORPORATION to the user. This drawing is loaned for mutual assistance and is subject to recall at any time.

SIZE	CODE IDENT. NO.	DWG NO.	ISSUE
A	82679	PM 1389	A
SCALE 1:1		SHEET OF	