

APPLICATION			REVISIONS							
QTY	MODEL USED ON	ASS'Y NO.	LTR	DESCRIPTION	DATE	E.M.N.NO	DRAFT	CHKD	APPD	
1	HFSR-4		X	EXP. RELEASE	4-10-68					
			X ₁	OBSOLETE NOTE ADDED	5-7-68					
			Ø	ORIG. RELEASE FOR PROD.	5.8.68	Ø	R.B.			

OBSOLETE

ADDED TO DI 103

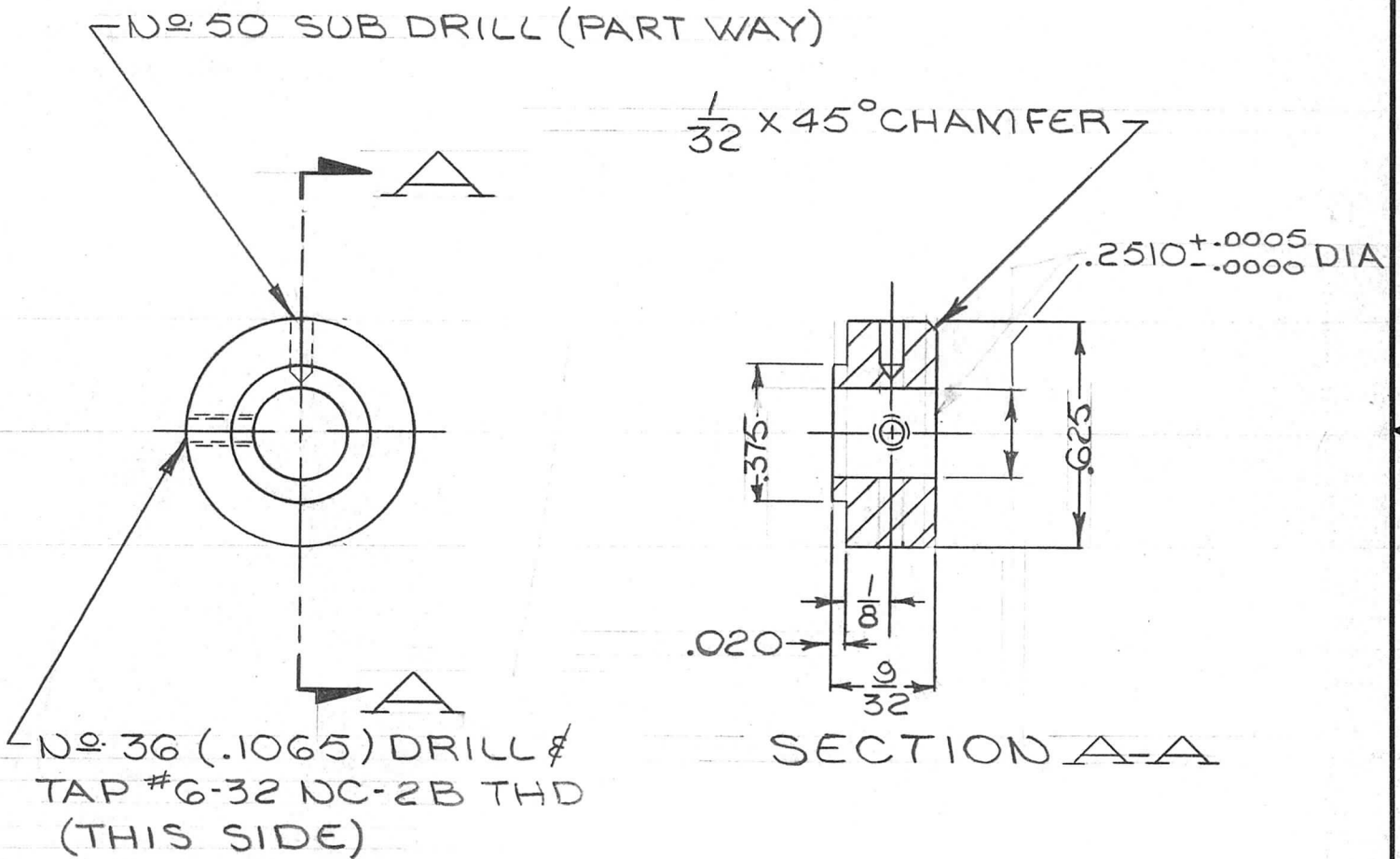

UNLESS OTHERWISE SPECIFIED DIMENSIONS ARE IN INCHES AND INCLUDE CHEMICALLY APPLIED OR PLATED FINISHES		REQ'D	ITEM	PART NUMBER	DESCRIPTION	SYM.	
DECIMALS: .X ± .05, .XX ± .01, .XXX ± .005; FRACTIONS: 1/64, ANGLES: 0° - 30'		HOGAN		LIST OF MATERIAL SK3252-004-26 X ₁			
MATERIAL H.H. BRASS		FINAL APPROVAL	DATE	THE TECHNICAL MATERIEL CORP. MAMARONECK, NEW YORK HUB, DIAL			
FINISH S135 NICKEL PLATE		MECH. DES.	DATE				
S401-451		ELECT. DES.	DATE				
		CHECKED	DATE				
NOTICE TO PERSONS RECEIVING THIS DRAWING		DRAWN	DATE	SIZE	CODE IDENT. NO.	DWG NO.	ISSUE
THE TECHNICAL MATERIEL CORPORATION claims proprietary right in the material disclosed hereon. This drawing is issued in confidence for engineering information only and may not be reproduced or used to manufacture anything shown hereon without permission from THE TECHNICAL MATERIEL CORPORATION to the user. This drawing is loaned for mutual assistance and is subject to recall at any time.		J. Wachman	4-10-68	A	82679	PM 1366	Ø

SCALE	2:1	SHEET	OF
-------	-----	-------	----