

REQ. PER UNIT	USED ON		
	MODEL	ASS'Y. NO.	DATE
1	TLAA-2.5K		11-30-66
1	RAK-110-2		

PM1332  $\emptyset$

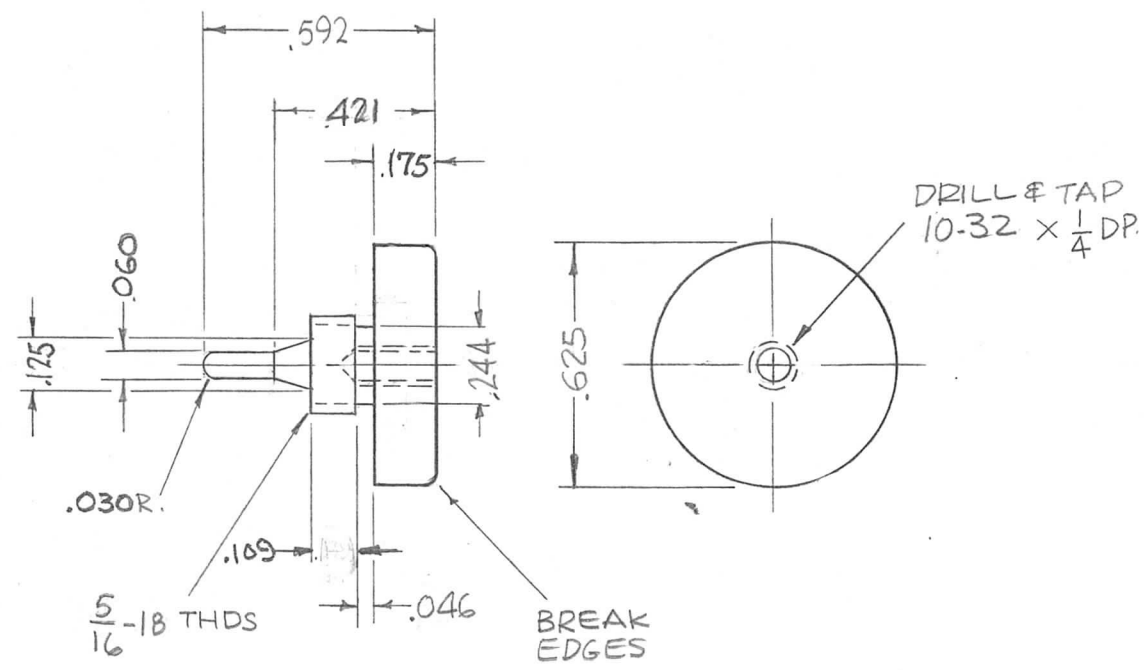

MATES WITH PX1007

SYM	DESCRIPTION	DATE	CH. NO.	DRAFTS	CHECKER	ENG. APP.	REQ. ITEM	PART NO.	F. BUDETTI DESCRIPTION	SYMBOL	
$\emptyset$	ORIGINAL RELEASE FOR PRODUCTION	3.1.67		WHA			AS SHOWN		THE TECHNICAL MATERIEL CORP. MAMARONECK, NEW YORK	$\emptyset$	
X <sub>1</sub>	5/16-18 WAS 1/4-20, 224 WAS 187	1-19-67	X <sub>1</sub>	WHA	WHA	WHA	STOCK SIZE				
X	EXP. RELEASE	11-30-66	X	WHA	WHA	WHA	BRASS	BUTTON, CONTACT			
UNLESS OTHERWISE SPECIFIED DIMENSIONS ARE IN INCHES AND INCLUDE CHEMICALLY APPLIED OR PLATED FINISHES							MATERIAL				
SCALE 2:1							HALF HARD		DRAWN [Signature] 2/28/67		FINAL APPROVAL [Signature]
DECIMALS .X ± .05 .XX ± .01 .XXX ± .005							TYPE & TEMPER 5245 SILVER PLATE 5423 SILVER KOTE		HEAT TREAT. SPEC.		FINISH & SPEC. NO.
TOLERANCES							FRACTIONS ± 1/64 ANGLES ± 0° 30'		ELEC. DES. APP.		MECH. DES. APP.
CODE A									PM1332 $\emptyset$		

M 11