

| | | | | | |
|---------------|-----------|------------|--------|--------|---|
| REQ. PER UNIT | USED ON | | | PM1253 | Ø |
| | MODEL | ASS'Y. NO. | DATE | | |
| 1 | TST()10K | | 5-5-65 | | |

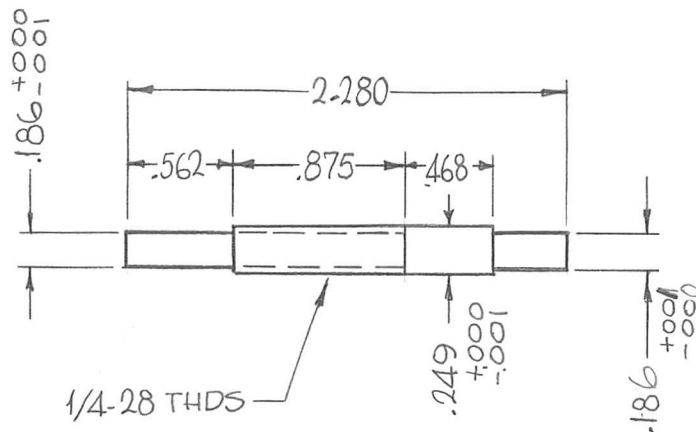

| REQ. ITEM | PART NO. | F. BUDETTI DESCRIPTION | | | | SYMBOL |
|---|---------------------------------|--|-----------------|----------|------------|-----------|
| | AS NOTED | THE TECHNICAL MATERIEL CORP. MAMARONECK, NEW YORK | | | | |
| | STOCK SIZE | SHAFT, PRECISION | | | | |
| Ø | ORIGINAL RELEASE FOR PRODUCTION | 4/26/67 | Ø | CV | <i>FW</i> | |
| SYM | DESCRIPTION | DATE | CH. NO. | DRAFTS | CHECKER | ENG. APP. |
| UNLESS OTHERWISE SPECIFIED DIMENSIONS ARE IN INCHES AND INCLUDE CHEMICALLY APPLIED OR PLATED FINISHES | | SCALE 1:1 | | | | |
| DECIMALS .X ± .05 .XX ± .01 .XXX ± .005 | TOLERANCES | FRACTIONS ± 1/64 ANGLES ± 0° 30' | CODE A | | | |
| | #303 | | | | <i>SRG</i> | |
| | TYPE & TEMPER | HEAT TREAT. SPEC. | | | DRAWN | CHECKED |
| | 5104 PASSIVATE | | | | <i>ad</i> | <i>FW</i> |
| | FINISH & SPEC. NO. | ELEC. DES. APP. | MECH. DES. APP. | PM1253 Ø | | |