

REQ. PER UNIT	USED ON			PM1229	Ø
	MODEL	ASS'Y. NO.	DATE		
2	RFTA-1	AS226	3-8-65		

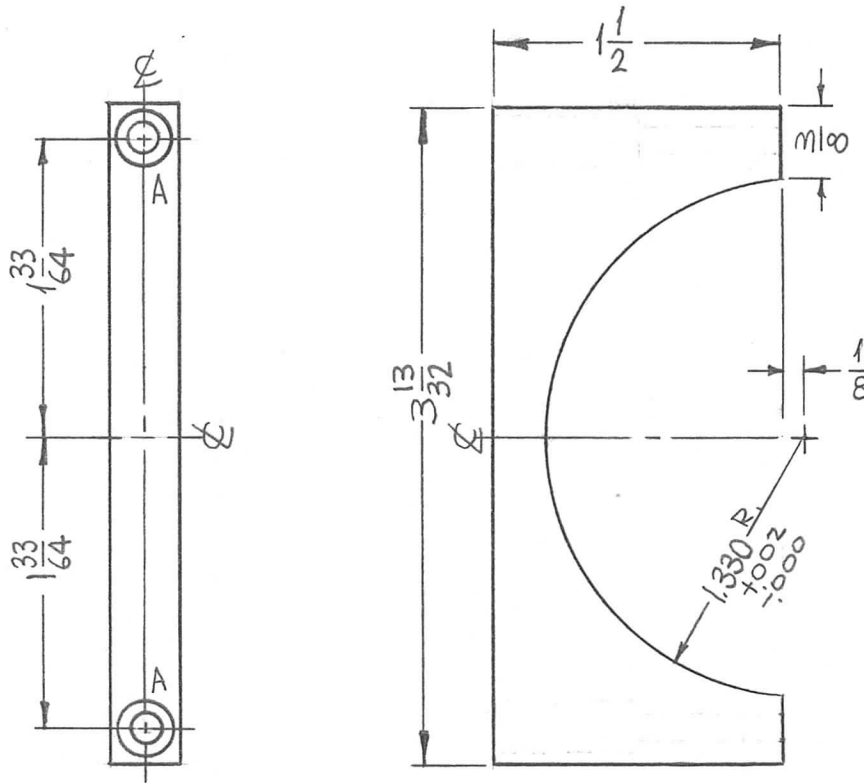

HOLES:
 A ~ DRILL 11/64 DIA. THRU
 C'BORE 9/32 DIA X
 3/4 DEEP.
 (2REQ.)

REF: LD 1944-

Ø	ORIGINAL RELEASE FOR PRODUCTION	5/20/66	Ø	C.V			REQ. ITEM	PART NO.	F. BUDETTI	DESCRIPTION	SYMBOL	
X ₁	FINISH WAS S404	4-15-65	X ₁	SRG	OK		3/8 THICK		THE TECHNICAL MATERIEL CORP. MAMARONECK. NEW YORK			
X	EXP. RELEASE	3-8-65	X	SRG			STOCK SIZE		SUPPORT, CAPACITOR			
							ALUMINUM					
SYM	DESCRIPTION	DATE	CH. NO.	DRAFTS	CHECKER	ENG. APP.	MATERIAL					
UNLESS OTHERWISE SPECIFIED DIMENSIONS ARE IN INCHES AND INCLUDE CHEMICALLY APPLIED OR PLATED FINISHES		SCALE		1:1			2024-T4		SRG	OK	OK	OK
DECIMALS .X ± .05 .XX ± .01 .XXX ± .005	TOLERANCES	FRACTIONS ± 1/64 ANGLES ± 0° 30'	CODE A				TYPE & TEMPER	HEAT TREAT. SPEC.	DRAWN	CHECKED	FINAL APPROVAL	
							S245 SILVER PLATE S423 SILVER KOTE		AA 5/19/66	OK	PM1229 Ø	
							FINISH & SPEC. NO.		ELEC. DES. APP.	MECH. DES. APP.		