

REQ. PER UNIT	USED ON			PM1200	Ø
	MODEL	ASS'Y. NO.	DATE		
2	RFTA-1		A4186		

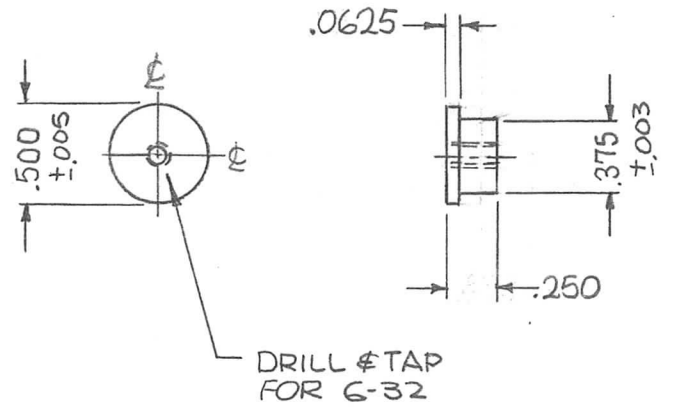

REQ.	ITEM	PART NO.	F. BUDETTI DESCRIPTION				SYMBOL					
Ø	ORIGINAL RELEASE FOR PRODUCTION	4/26/67	Ø	CV	<i>SRG</i>	AS NOTED		THE TECHNICAL MATERIEL CORP. MAMARONECK, NEW YORK				
X ₁	250 WAS 375, 0625 WAS .1875	1-25-65	X ₁	SRG		STOCK SIZE						
X	EXP. RELEASE	1-15-65	X	SRG		BRASS						
SYM	DESCRIPTION	DATE	CH. NO.	DRAFTS	CHECKER	ENG. APP.	MATERIAL					
UNLESS OTHERWISE SPECIFIED DIMENSIONS ARE IN INCHES AND INCLUDE CHEMICALLY APPLIED OR PLATED FINISHES		SCALE		1:1			1/2 H	SRG	<i>SRG</i>			
DECIMALS .X ± .05 .XX ± .01 .XXX ± .005		FRACTIONS ± 1/64 ANGLES ± 0° 30'		TOLERANCES		CODE A	TYPE & TEMPER	HEAT TREAT. SPEC.		DRAWN	CHECKED	FINAL APPROVAL
							NONE		<i>ad</i>	<i>SRG</i>	PM1200	Ø
							FINISH & SPEC. NO.	ELEC. DES. APP.	MECH. DES. APP.			