

REQ. PER UNIT	USED ON			PM1188 A
	MODEL	ASS'Y. NO.	DATE	
1	TST-10K		5-9-65	

HOLES -
 A-DRILL & TAP 8-32 THD THRU 3 REQ.
 B-DRILL & TAP 1/4-20 THD 1 REQ.

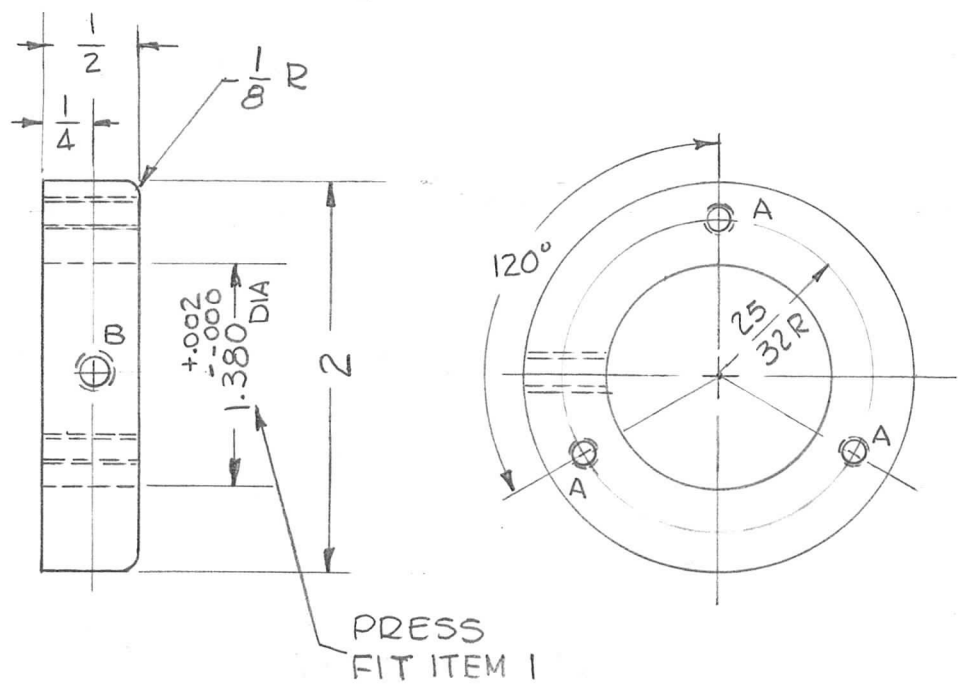

							1	1	PX1294	PLASTIC ADAPTER			
							REQ.	ITEM	PART NO.	DESCRIPTION	SK 3129-PM23	SYMBOL	
A	ITEM 1 WAS BB133-1			3-8-63	22007	GDL	THE TECHNICAL MATERIEL CORP. MAMARONECK, NEW YORK						
Ø	ORIGINAL RELEASE FOR PRODUCTION			6/17/66	Ø	CV	STOCK SIZE						
X ₁	DIM. 1.380 WAS 1.022 ± .000 BB133-1 ADDED			6-9-65	X ₁	GDL	BRASS						
UNLESS OTHERWISE SPECIFIED DIMENSIONS ARE IN INCHES AND INCLUDE CHEMICALLY APPLIED OR PLATED FINISHES							MATERIAL						
SCALE 1:1							HALF HARD		G.D.L. Hde 6/15/66			FINAL APPROVAL	
DECIMALS .X ± .05 .XX ± .01 .XXX ± .005							TYPE & TEMPER S135 NICKEL PLATE, BRIGHT						
FRACTIONS ± 1/64 ANGLES ± 0° 30'							FINISH & SPEC. NO.						
TOLERANCES							ELEC. DES. APP.		MECH. DES. APP.		PM1188 A		