

REQ. PER UNIT	USED ON		PM1183 \emptyset
	MODEL	ASS'Y. NO.	
1	TST-10K		11-17-64

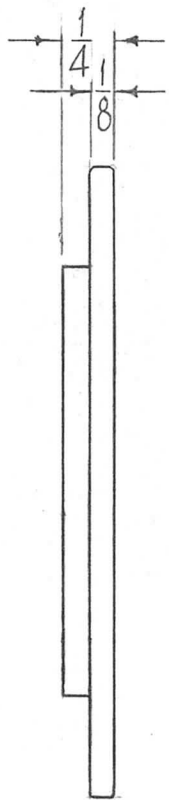
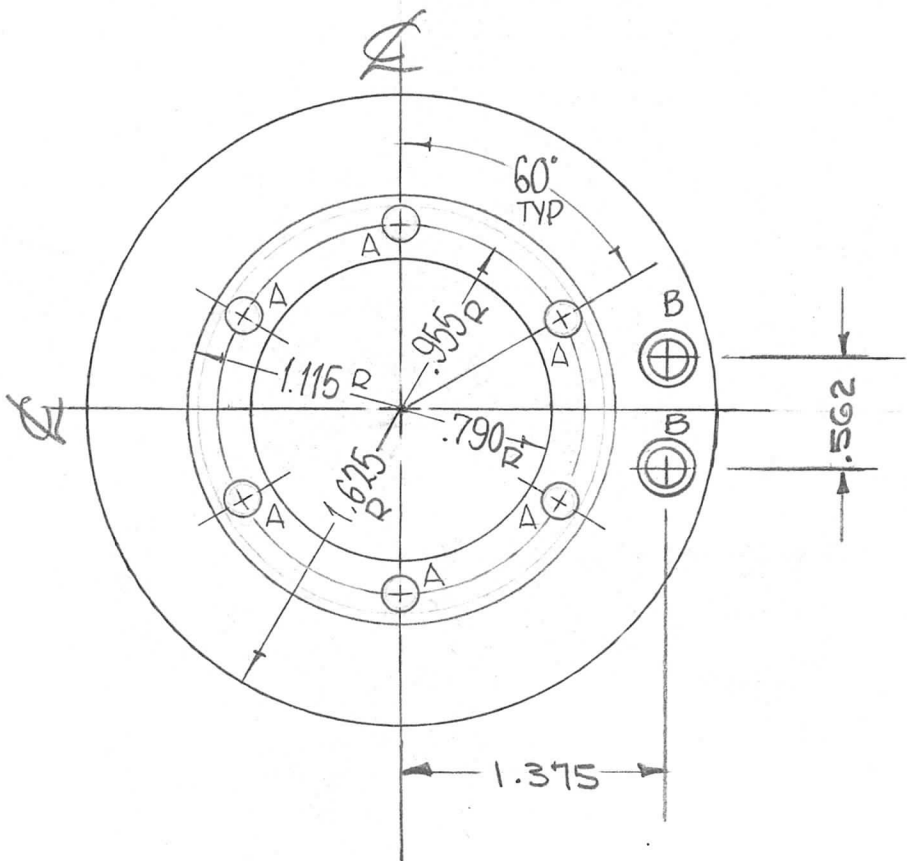

HOLES REQ.

A- 13/64 DIA. THRU 6

B- DRILL #18 THRU
C'SK 82° TO .337 DIA. 2

UNLESS OTHERWISE SPECIFIED

- POLISH BEFORE PLATING.
- S245 SILVER PLATE BRIGHT
- S423 IRIDIOTE 180 SILVER KOTE
- ROUND ALL CORNERS & EDGES 1/32 R.
- ALL DIMENSIONS APPLY AFTER PLATING.

REQ.	ITEM	PART NO.	F. BUDETTI	DESCRIPTION	PM13	SYMBOL	
\emptyset	ORIGINAL RELEASE FOR PRODUCTION	6/17/66	\emptyset	CV	HOE	AS NOTED	
XI	② "B" HOLES ADDED	11-19-65	-M-	Jc	alc	STOCK SIZE	
X	EXP. RELEASE	12-2-64	X	SRG		BRASS	
SYM	DESCRIPTION	DATE	CH. NO.	DRAFTS	CHECKER	ENG. APP.	
UNLESS OTHERWISE SPECIFIED DIMENSIONS ARE IN INCHES AND INCLUDE CHEMICALLY APPLIED OR PLATED FINISHES		SCALE	1:1				HALF HARD
DECIMALS	FRACTIONS	CODE	TYPE & TEMPER				HEAT TREAT. SPEC.
.X \pm .05	\pm 1/64	A	SEE NOTES				DRAWN
.XX \pm .01	ANGLES		FINISH & SPEC. NO.				CHECKED
.XXX \pm .005	\pm 0° 30'		ELEC. DES. APP.				MECH. DES. APP.
			John C. Biele				John C. Biele
			Hole 1/56 02 B				PM1183 \emptyset