

REQ. PER UNIT	USED ON		
	MODEL	ASS'Y. NO.	DATE
1	TST(1)10K	AM124	2-24-66
1	GPT10KLF		2-7-66

PM1171 \emptyset

(3) DRILL & TAP FOR 10-32 THRU 120° APART ON A 3/4 DIA.

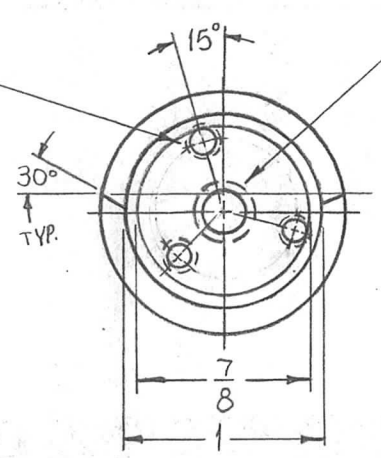

DRILL & TAP FOR 5/16-18

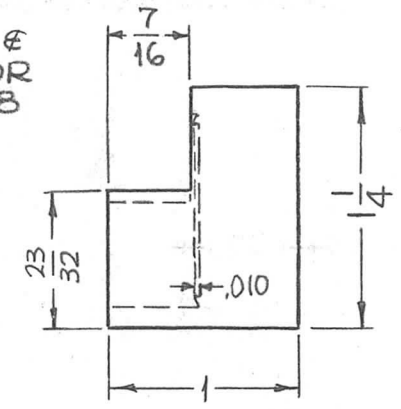

SYM	DESCRIPTION	DATE	CH. NO.	DRAFTS	CHECKER	ENG. APP.	REQ. ITEM	PART NO.	BUDETTI DESCRIPTION	SYMBOL			
\emptyset	ORIGINAL RELEASE	4/15/66	\emptyset			<i>AD</i>			THE TECHNICAL MATERIEL CORP. MAMARONECK, NEW YORK	PM1171 \emptyset			
X2	.515 DIM DELETED, TAP MADE TO GO THRU	8/23/65	MA	JC		<i>GRE</i>	1 1/4 DIA.	STOCK SIZE					
X1	P/N WAS PM1170 (ERROR), DWG WAS ALSO P/O A4113, LATCH ASS'Y	8/16/65	MA	JC		<i>GRE</i>	BRASS	HOLDER, LATCH					
UNLESS OTHERWISE SPECIFIED DIMENSIONS ARE IN INCHES AND INCLUDE CHEMICALLY APPLIED OR PLATED FINISHES							SCALE	MATERIAL					
							HALF HARD FM		SRC	<i>OCB</i>	<i>M. H. King</i>		
							TYPE & TEMPER	HEAT TREAT. SPEC.	DRAWN	CHECKED	FINAL APPROVAL		
DECIMALS .X \pm .05 .XX \pm .01 .XXX \pm .005							FRACTIONS \pm 1/64 ANGLES \pm 0° 30'	CODE	FINISH & SPEC. NO.			ELEC. DES. APP.	MECH. DES. APP.
TOLERANCES							A	A4113			NONE		