

REQ. PER UNIT	USED ON			PM1166	Ø
	MODEL	ASS'Y. NO.	DATE		
2	VLLA-1		1-3-65		

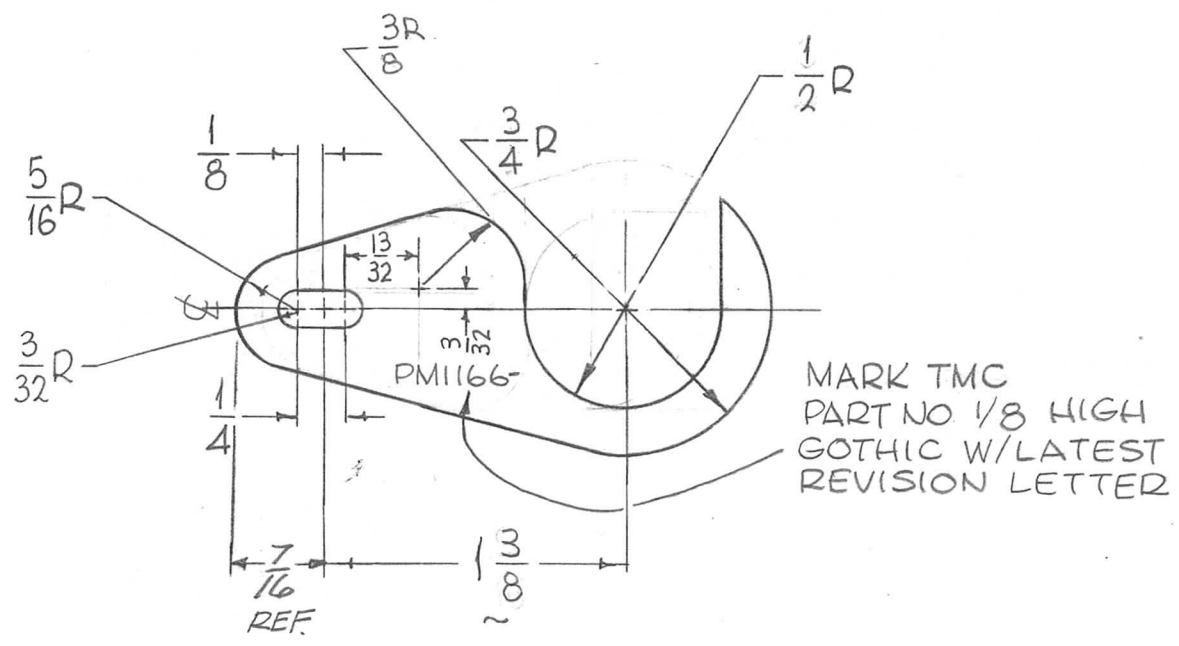

REQ.	ITEM	PART NO.	BUDETTI	DESCRIPTION	SYMBOL							
Ø	ORIGINAL RELEASE FOR PRODUCTION	11-65	Ø	J.V.V.								
X2	1-3/8 WAS 1-9/16, PICTORIAL REVISED	11-11-65	X2	J.P.								
X1	ADDED SPEC S245	2/9/65		J.L.								
SYM	DESCRIPTION	DATE	CH. NO.	DRAFTS	CHECKER	ENG. APP.						
UNLESS OTHERWISE SPECIFIED DIMENSIONS ARE IN INCHES AND INCLUDE CHEMICALLY APPLIED OR PLATED FINISHES							SCALE	1:1				
DECIMALS .X ± .05 .XX ± .01 .XXX ± .005							TOLERANCES	FRACTIONS ± 1/64 ANGLES ± 0° 30'				
CODE A												
HALF HARD								S245 SILVER PLATE				
TYPE & TEMPER							HEAT TREAT. SPEC.	DRAWN		CHECKED	FINAL APPROVAL	
FINISH & SPEC. NO.							ELEC. DES. APP.	MECH. DES. APP.		PM1166	Ø	