

REQ. PER UNIT	USED ON			PM1165 \emptyset
	MODEL	ASS'Y. NO.	DATE	
2	GPT10KLF	AX531	6-17-66	

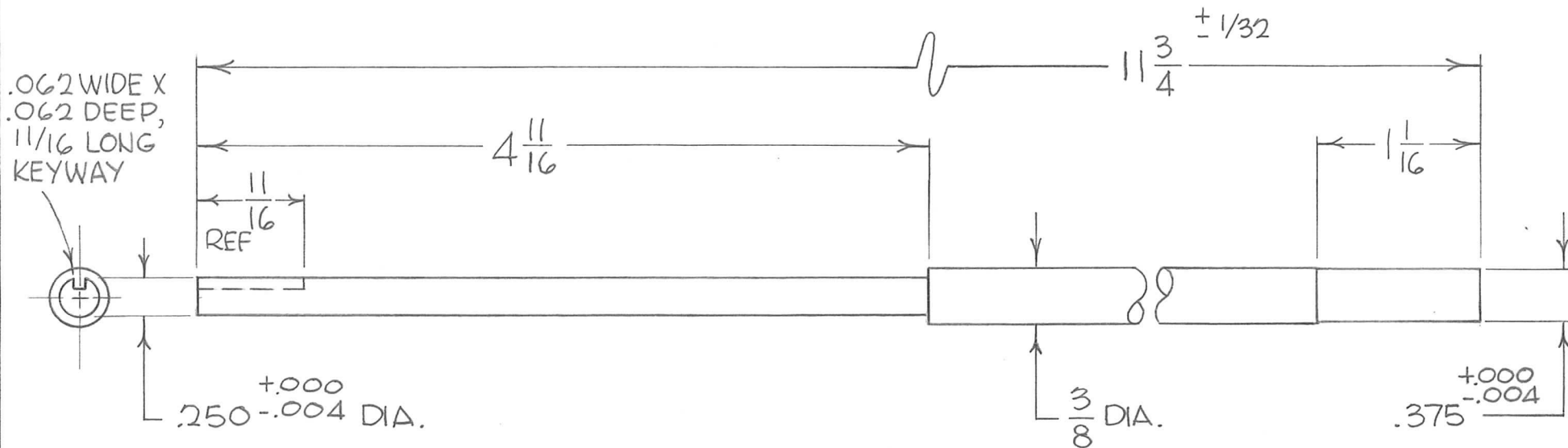

REQ.	ITEM	PART NO.	BUDETTI	DESCRIPTION	SYMBOL
		AS NOTED	THE TECHNICAL MATERIEL CORP.		
		STOCK SIZE	MAMARONECK. NEW YORK		
\emptyset	ORIGINAL RELEASE FOR PRODUCTION	6-22-66	\emptyset	SHAFT, DRIVE	
SYM	DESCRIPTION	DATE	CH. NO.	CHECKER	ENG. APP.
UNLESS OTHERWISE SPECIFIED DIMENSIONS ARE IN INCHES AND INCLUDE CHEMICALLY APPLIED OR PLATED FINISHES		SCALE			
DECIMALS .X \pm .05 .XX \pm .01 .XXX \pm .005	TOLERANCES	FRACTIONS \pm 1/64 ANGLES \pm 0° 30'	CODE		
			303	Jc	QC/B
			TYPE & TEMPER	HEAT TREAT. SPEC.	DRAWN
			S104-PASSIVATE		CHECKED
			FINISH & SPEC. NO.	ELEC. DES. APP.	MECH. DES. APP.
					PM1165 \emptyset

1/16 1/16 1