

REQ. PER UNIT	USED ON			PM1144 Ø
	MODEL	ASS'Y. NO.	DATE	
1	HFIR-1		10-22-64	

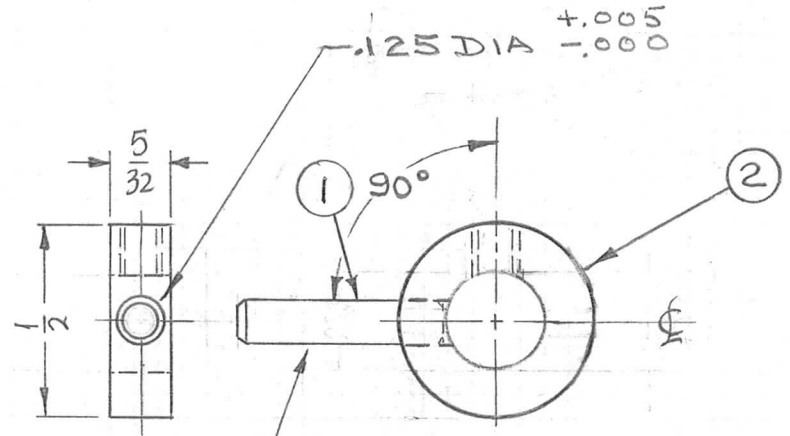

NOTE:
REMOVE BURRS & SHARP EDGES

1	2	PM786-3	COLLAR, SHAFT		
1	1	PN116-A-49-5	PIN, DOWEL		
REQ.	ITEM	PART NO.	EATON	DESCRIPTION	SYMBOL
Ø	ORIGINAL RELEASE FOR PRODUCTION	3-19-65	Ø	Ø I.	
X ₁	PIN DETAIL DELE; IT.(1) ADD. TO B/M	12-7-64	X ₁	Ø L.	
X	EXP. RELEASE	10-22-64	X	SRG	
SYM	DESCRIPTION	DATE	CH. NO.	DRAFTS	CHECKER
UNLESS OTHERWISE SPECIFIED DIMENSIONS ARE IN INCHES AND INCLUDE CHEMICALLY APPLIED OR PLATED FINISHES		SCALE	2:1		
DECIMALS	FRACTIONS	CODE			
.X ± .05	± 1/64	A			
.XX ± .01	ANGLES				
.XXX ± .005	± 0° 30'				
TOLERANCES					
1/2 DIA	STOCK SIZE	303	THE TECHNICAL MATERIEL CORP. MAMARONECK, NEW YORK		
STAINLESS STEEL	MATERIAL	SRG	ACTUATOR, LINK		
TYPE & TEMPER	HEAT TREAT. SPEC.	SRG	Q	M. Key 3/19/65	
5404 YELLOW IRIDITE	FINISH & SPEC. NO.	SRG	B/B	PM1144 Ø	