

REQ. PER UNIT	USED ON			PM1119	Ø
	MODEL	ASS'Y. NO.	DATE		
1	TTC-1				

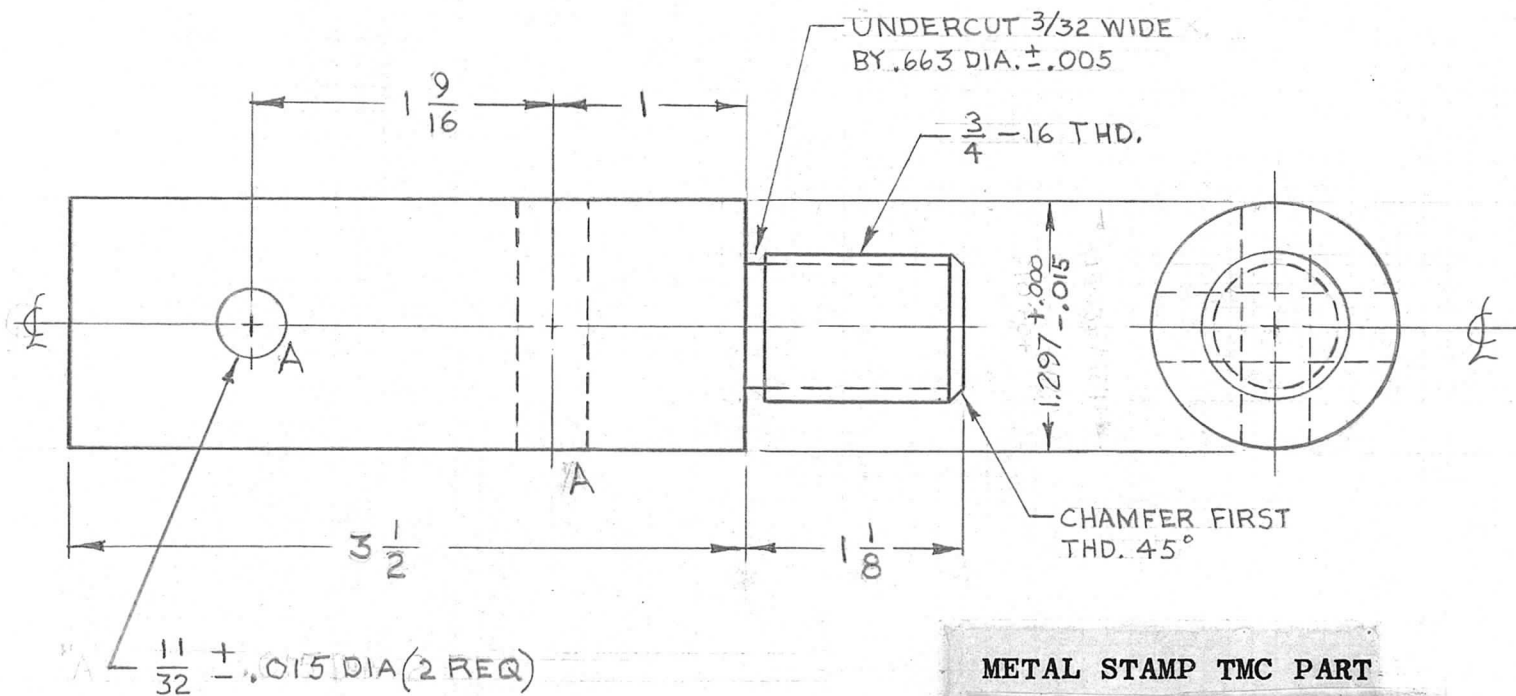

METAL STAMP TMC PART NO. 1/8 HIGH GOTHIC. WITH LATEST REV. LETTER.

REMOVE ALL BURRS AND SHARP EDGES.

						REQ. ITEM	PART NO.	A. DUDDELES	DESCRIPTION	SYMBOL		
							STOCK SIZE		THE TECHNICAL MATERIEL CORP. MAMARONECK, NEW YORK			
Ø	RELEASE FOR PROD.	9.30.64		9L			STAINLESS STEEL		ADAPTER, ANTENNA			
X	EXPERIMENTAL RELEASE	9.30.64		9L								
SYM	DESCRIPTION	DATE	CH. NO.	DRAFTS	CHECKER	ENG. APP.	MATERIAL					
UNLESS OTHERWISE SPECIFIED DIMENSIONS ARE IN INCHES AND INCLUDE CHEMICALLY APPLIED OR PLATED FINISHES		SCALE		1:1					9-Lwara @ 9-30-64	RAL		
DECIMALS X ± .05 .XX ± .01 .XXX ± .005	TOLERANCES	FRACTIONS ± 1/64 ANGLES ± 0° 30'	CODE				TYPE & TEMPER	HEAT TREAT. SPEC.	DRAWN	CHECKED	FINAL APPROVAL	
			A				PASSIVATE		9-30-64		PM1119	Ø
							FINISH & SPEC. NO.	ELEC. DES. APP.	MECH. DES. APP.			