

REQ. PER UNIT	USED ON			PM 1101	Ø
	MODEL	ASS'Y. NO.	DATE		
1	VLRB-1		7-1-64		

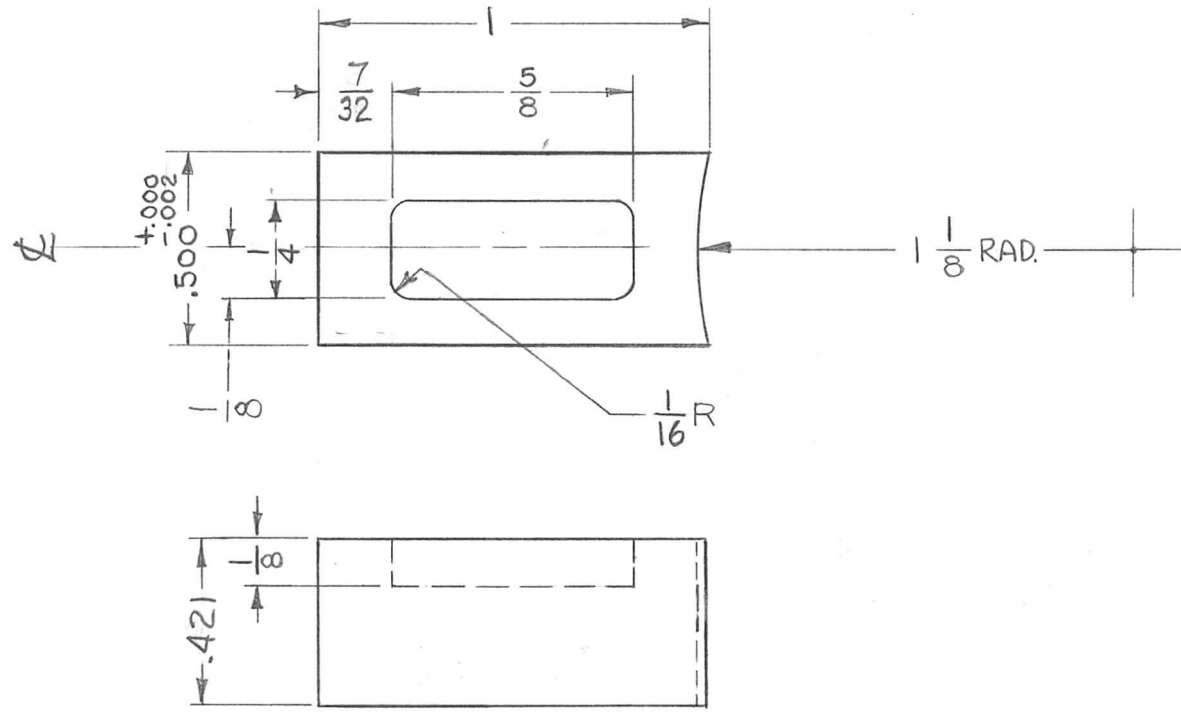

REMOVE ALL BURRS AND SHARP EDGES

ORIGINAL RELEASE FOR PRODUCTION				9/17/65	Ø	DVV		REQ. ITEM	PART NO.	T. KRUY	DESCRIPTION	POSE	SYMBOL				
X2	S135 ADDED TO FINISH & SPEC NO.		9/14/65	-A	JC		AS NOTED		THE TECHNICAL MATERIEL CORP. MAMARONECK, NEW YORK								
X1	DIM .421 WAS 7/16 METAL STAMP NOTE DELETED		12-2-64		GD-L		STOCK SIZE		SLIDE, LOCK (YOKE)								
X	EXPER. RELEASE		7/1/64		LSB		BRASS										
SYM	DESCRIPTION		DATE	CH. NO.	DRAFTS	CHECKER	ENG. APP.	MATERIAL									
UNLESS OTHERWISE SPECIFIED DIMENSIONS ARE IN INCHES AND INCLUDE CHEMICALLY APPLIED OR PLATED FINISHES			SCALE 2:1				1/2 HARD		-H	LSB 7.1.64							
DECIMALS .X ± .05 .XX ± .01 .XXX ± .005		TOLERANCES		FRACTIONS ± 1/64 ANGLES ± 0° 30'		CODE A		TYPE & TEMPER		HEAT TREAT. SPEC.		DRAWN		CHECKED		FINAL APPROVAL	
								S135 NICKEL PLATE						PM 1101		Ø	
								FINISH & SPEC. NO.		ELEC. DES. APP.		MECH. DES. APP.					