

REQ. PER UNIT	USED ON			PM 1100	Ø
	MODEL	ASS'Y. NO.	DATE		
1	VLRB-1		8/28/64		

METAL STAMP TMC PART NO. 1/8 HIGH GOthic WITH LATEST REV. LETTER

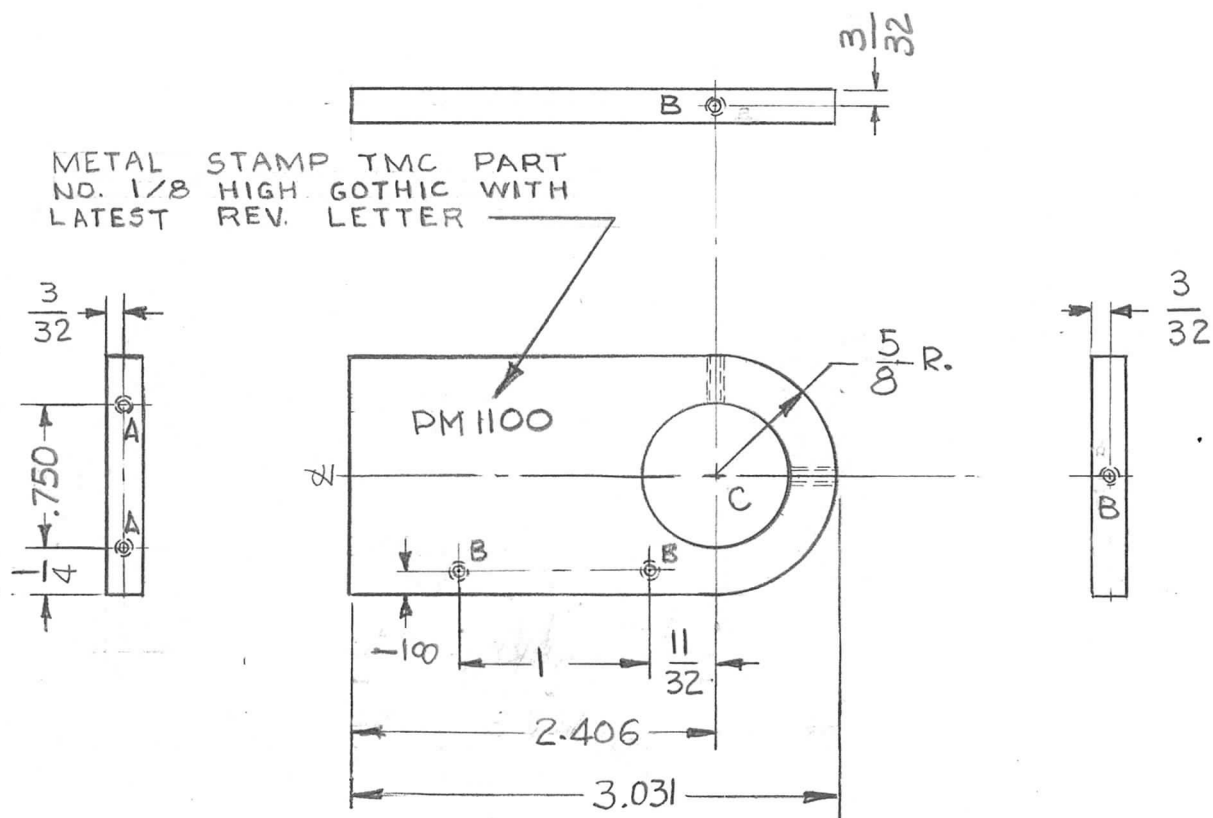

HOLES:
 A- DR & TAP 4-40 X 1/2 DEEP (2 REQ)
 B- DR & TAP 4-40 THRU (4 REQ.)
 C- .750 DIA. (1 REQ.)

REMOVE ALL BURRS AND SHARP EDGES

SYM	DESCRIPTION	DATE	CH. NO.	DRAFTS	CHECKER	ENG. APP.	REQ. ITEM	PART NO.	DESCRIPTION	SYMBOL		
Ø	ORIGINAL RELEASE FOR PRODUCTION	4.9.65	Ø	gfi				3/16 THICK	THE TECHNICAL MATERIEL CORP. MAMARONECK, NEW YORK	Ø		
X ₁	(2) 4-40 HOLES ADDED	10/28/64						STOCK SIZE				
X	EXPERIMENTAL REL.	8/28/64		lob				ALUMINUM				
								MATERIAL	BRACKET DIAL			
UNLESS OTHERWISE SPECIFIED DIMENSIONS ARE IN INCHES AND INCLUDE CHEMICALLY APPLIED OR PLATED FINISHES		SCALE					2024-T3		lob	@	Ø	
		1:1					TYPE & TEMPER	HEAT TREAT. SPEC.	DRAWN	CHECKED	FINAL APPROVAL	
DECIMALS .X ± .05 .XX ± .01 .XXX ± .005		FRACTIONS ± 1/64 ANGLES ± 0° 30'		CODE A			S404 YEL. IRIDITE				PM 1100	Ø
TOLERANCES					FINISH & SPEC. NO.		ELEC. DES. APP.		MECH. DES. APP.			