

IF IT IS FOUND DESIRABLE TO CHANGE ANY TOLERANCE OR OTHER DETAIL SPECIFIED ON THIS DRAWING NOTIFY THE PURCHASER PROMPTLY.

PM-196 B

MAXIMUM ALLOWABLE TOLERANCES HAVE BEEN DETERMINED AND DEVIATIONS WILL BE CAUSE FOR REJECTION. REMOVE ALL BURRS AND SHARP EDGES

REQ PER UNIT	USED ON			
	MODEL	PROJECT NO.	ASS'Y. NO.	DATE
1	VOX		A-631	11-23-54
3	RSC-2			11-23-54

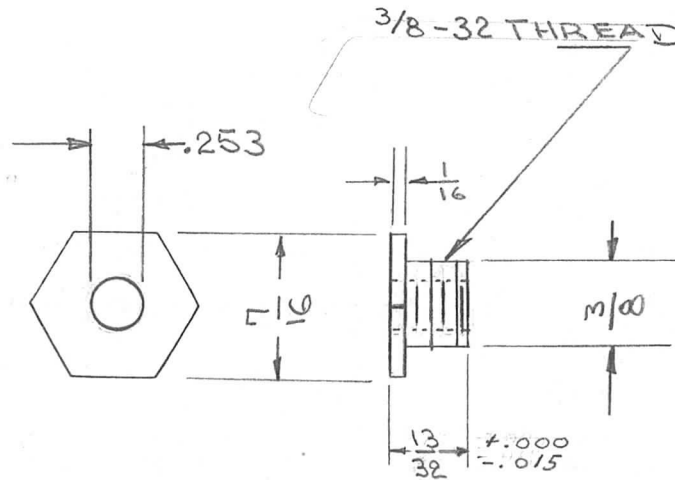

NOTE
 TO BE SUPPLIED BY MFR.
 ONE HEX. NUT, 3/8-32 THREAD, 3/32 THICK
 7/16 ACROSS FLATS.
 TMC EQUIV. NTH 3732 BNIG - NUT, HEX.

NOTE
 DIM. SHOWN ARE AFTER PLATING

B	2	DIM. ADDED	12/24/56	2	MIC	JINDE	ALLO
	1	FINISH WAS CADMIUM PLATED	11-23-54	1	P.B.	JARDE	
A	1	REDRAWN					
ISSUE	ITEM	CHANGED FROM	DATE	CN. NO.	DRAFTS	CHECKER	ENG. APP.

TOLERANCES		SCALE
ALL OTHERS	DEC. DIM. ± FRAC. DIM. ± ANGULAR DIM. ±	DRILL, PUNCH, COMMERCIAL STOCK SIZES AND MANUFACTURERS TOLERANCES ARE NOT INCLUDED.

REQ.	ITEM	PART NO.	DESCRIPTION	SYMBOL
		— # —	THE TECHNICAL MATERIEL CORP. MAMARONECK, NEW YORK	
		STOCK SIZE		
		BRASS	CALIBRATE CONTROL	
		MATERIAL	WEIGHT PER PC.	
		— # —	PANEL BEARING	
		TYPE & TEMPER	P.B. 11-23, 54.	
		— # —	DRAWN	ELEC. DES. APP. MECH. DES. APP.
		HEAT TREAT. SPEC.	JARDE	
		NICKEL PLATE S-135	CHECKED	FINAL APPROVAL
		FINISH & SPEC. NO.	SUPERSEDES AMS 377	PM-196 B