

IF IT IS FOUND DESIRABLE TO CHANGE ANY TOLERANCE OR OTHER DETAIL SPECIFIED ON THIS DRAWING NOTIFY THE PURCHASER PROMPTLY.

RELEASED

PM-150 A

MAXIMUM ALLOWABLE TOLERANCES HAVE BEEN DETERMINED AND DEVIATIONS WILL BE CAUSE FOR REJECTION. REMOVE ALL BURRS AND SHARP EDGES

USED ON

MODEL	PROJECT NO.	ASS'Y. NO.	DATE
TWR-115	151	A-219	9-13-52

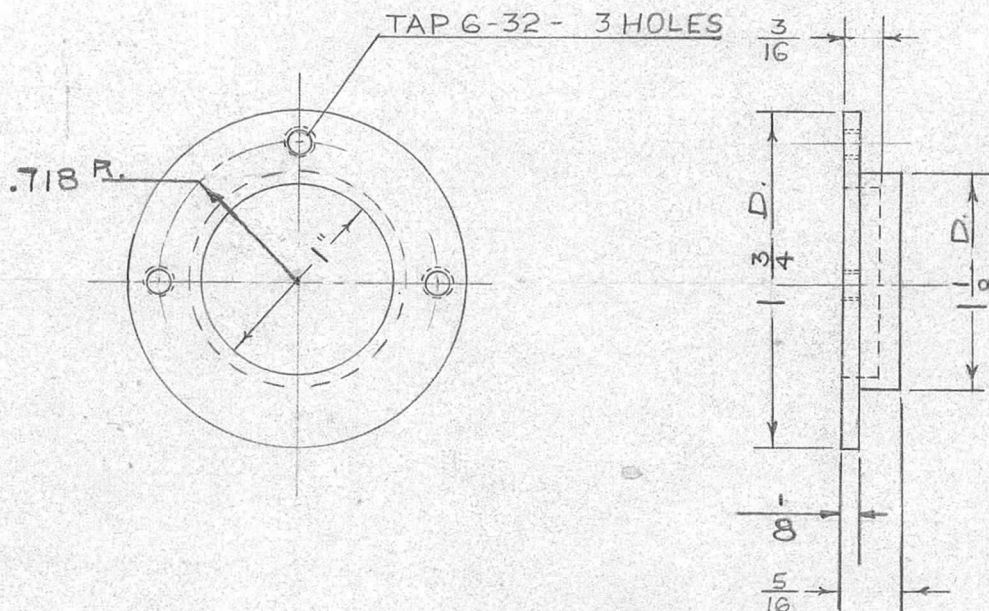

NOTE:
 1. S-101 (CAUSTIC DIP)
 2. S-151 (GREY WRINKLE PAINT)

REQ.	ITEM	PART NO.	DESCRIPTION	SYMBOL
		1 3/4 D.	THE TECHNICAL MATERIEL CORP. MAMARONECK, NEW YORK	
		ALUMINUM	COVER BDSS	
		115-T3		
		TYPE & TEMPER		
		HEAT TREAT. SPEC.		
		FINISH & SPEC. NO.		

ISSUE	ITEM	CHANGED FROM	DATE	CN. NO.	DRAFTS	CHECKER	ENG. APP.
A	1	1/8 WAS 3/32	7-9-52	1			[Signature]

TOLERANCES		SCALE
DEC. DIM. ±	.005	DRILL, PUNCH, COMMERCIAL STOCK
FRAC. DIM. ±	64	SIZES AND MANUFACTURERS
ANGULAR DIM. ±		TOLERANCES ARE NOT INCLUDED.

DRAWN	ELEC. DES. APP.	MECH. DES. APP.
[Signature]		[Signature]
CHECKED	FINAL APPROVAL	
11/6/52	PM-150 A	

IF IT IS FOUND DESIRABLE TO CHANGE ANY TOLERANCE OR OTHER DETAIL SPECIFIED ON THIS DRAWING NOTIFY THE PURCHASER PROMPTLY.

PM-150

MAXIMUM ALLOWABLE TOLERANCES HAVE BEEN DETERMINED AND DEVIATIONS WILL BE CAUSE FOR REJECTION. REMOVE ALL BURRS AND SHARP EDGES

TWR-115

USED ON

MODEL

PROJECT NO.

ASS'Y. NO.

DATE

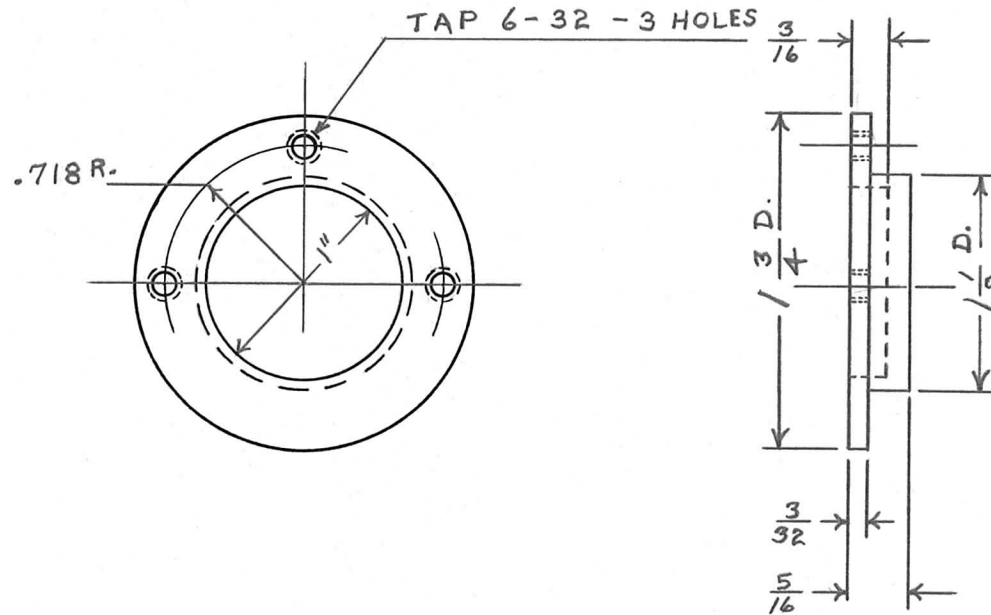

NOTE:

1. S-101 (CAUSTIC DIP)
2. S-151 (GREY WRINKLE PAINT)

REQ.	ITEM	PART NO.	DESCRIPTION	SYMBOL
		1 3/4 D.	TMC (Canada) LIMITED	
		STOCK SIZE	OTTAWA ONTARIO	
	ALUMINUM	—H—	COVER BOSS	
	MATERIAL	WEIGHT PER PC.	TAPE WINDING	
		1/5-73	BT 5/5/55	
		TYPE & TEMPER	DRAWN	ELEC. DES. APP. MECH. DES. APP.
		H		
		HEAT TREAT. SPEC.	CHECKED	FINAL APPROVAL
		SEE NOTE		PM-150
		FINISH & SPEC. NO.		

ISSUE	ITEM	CHANGED FROM	DATE	CN. NO.	DRAFTS	CHECKER	ENG. APP.
TOLERANCES				SCALE FULL SIZE			
ALL OTHERS	DEC. DIM. ± .005	DRILL, PUNCH, COMMERCIAL STOCK SIZES AND MANUFACTURERS TOLERANCES ARE NOT INCLUDED.					
	FRAC. DIM. ± 1/64						
	ANGULAR DIM. ±						