

IF IT IS FOUND DESIRABLE TO CHANGE ANY TOLERANCE OR OTHER DETAIL SPECIFIED ON THIS DRAWING NOTIFY THE PURCHASER PROMPTLY.

PM-139

MAXIMUM ALLOWABLE TOLERANCES HAVE BEEN DETERMINED AND DEVIATIONS WILL BE CAUSE FOR REJECTION. REMOVE ALL BURRS AND SHARP EDGES

TWR-115

USED ON

MODEL

PROJECT NO.

ASS'Y. NO.

DATE

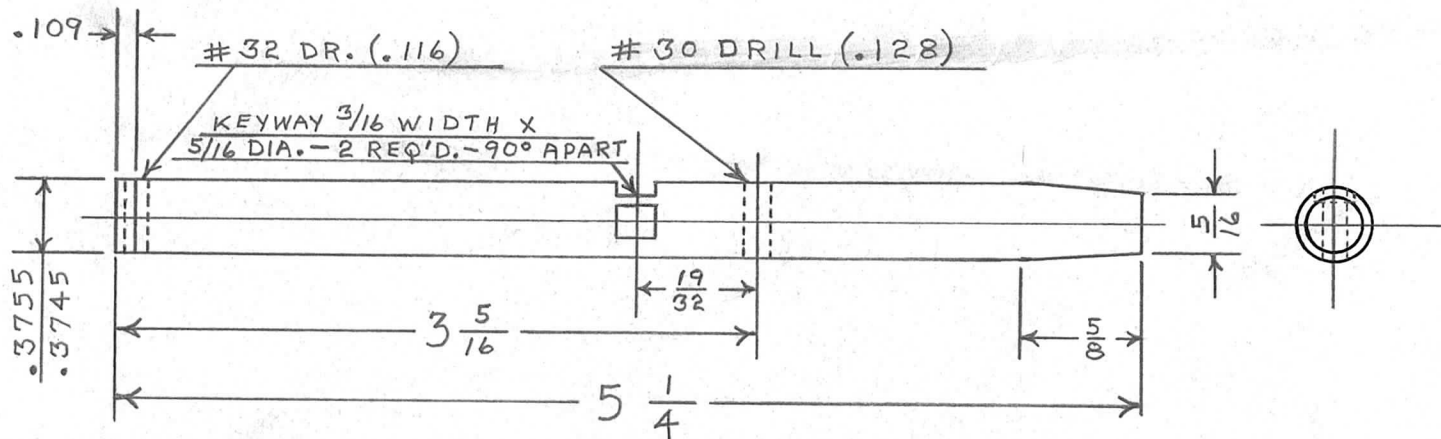

NOTICE TO PERSONS RECEIVING THIS DRAWING

THE TECHNICAL MATERIEL CORPORATION claims proprietary right in the material disclosed hereon. This drawing is issued in confidence for engineering information only and may not be reproduced or used to manufacture anything shown hereon without permission from THE TECHNICAL MATERIEL CORPORATION to the user. This drawing is loaned for mutual assistance and is subject to recall at any time.

Property of:

THE TECHNICAL MATERIEL CORPORATION
MAMARONECK, NEW YORK

REQ.	ITEM	PART NO.	DESCRIPTION	SYMBOL
	$\frac{3755}{3745}$ DIA.		TMC (Canada) LIMITED OTTAWA ONTARIO	
	STOCK SIZE			
	STAINLESS STEEL	#	GEAR SHAFT	
	MATERIAL	WEIGHT PER PC.	TAPE WINDER	
	303 OR 416		RT 11/5/55	
	TYPE & TEMPER		DRAWN	ELEC. DES. APP. MECH. DES. APP.
	#			
	HEAT TREAT. SPEC.		CHECKED	FINAL APPROVAL
	PASSIVATE S-104			PM-139
	FINISH & SPEC. NO.			

ISSUE	ITEM	CHANGED FROM	DATE	CN. NO.	DRAFTS	CHECKER	ENG. APP.
TOLERANCES			SCALE FULL SCALE				
ALL OTHERS	DEC. DIM. $\pm .005$ FRAC. DIM. $\pm 1/64$ ANGULAR DIM. \pm		DRILL, PUNCH, COMMERCIAL STOCK SIZES AND MANUFACTURERS TOLERANCES ARE NOT INCLUDED.				

IF IT IS FOUND DESIRABLE TO CHANGE ANY TOLERANCE OR OTHER DETAIL SPECIFIED ON THIS DRAWING NOTIFY THE PURCHASER PROMPTLY.

RELEASED

PM-139

MAXIMUM ALLOWABLE TOLERANCES HAVE BEEN DETERMINED AND DEVIATIONS WILL BE CAUSE FOR REJECTION. REMOVE ALL BURRS AND SHARP EDGES

USED ON

MODEL	PROJECT NO.	ASS'Y. NO.	DATE
TWR-115	151	A-215	9-23-52

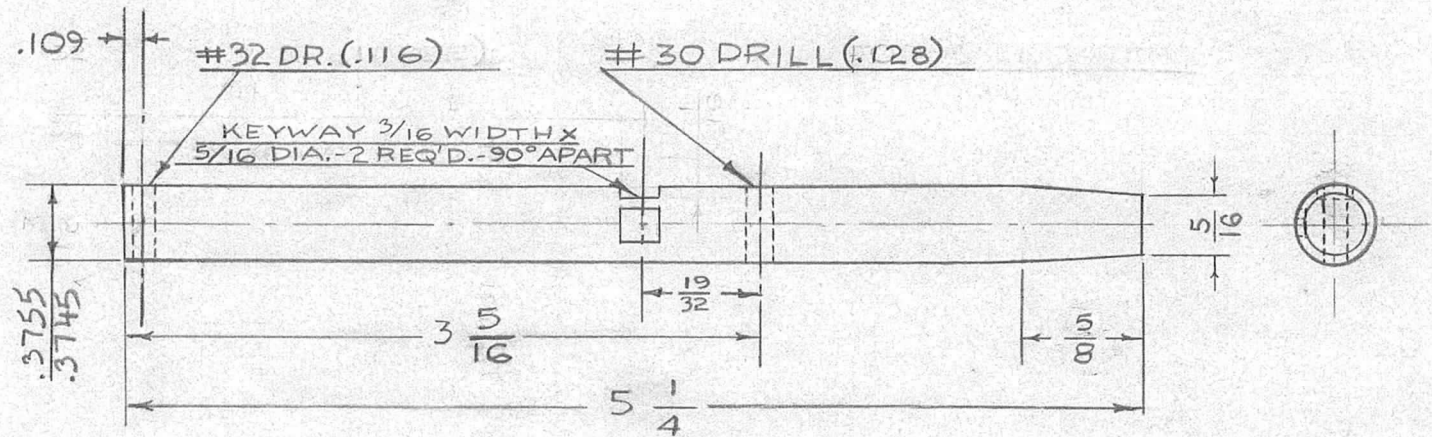

REQ.	ITEM	PART NO.	DESCRIPTION	SYMBOL
	.3755 .3745	DIA.	THE TECHNICAL MATERIEL CORP. MAMARONECK, NEW YORK	
	STOCK SIZE			
	STAINLESS STEEL		GEAR SHAFT	
	MATERIAL			
	303 OR 416			
	TYPE & TEMPER			
	HEAT TREAT. SPEC.			
	PASSIVATE S-104			
	FINISH & SPEC. NO.			

ISSUE	ITEM	CHANGED FROM	DATE	CN. NO.	DRAFTS	CHECKER	ENG. APP.
TOLERANCES		SCALE FULL SCALE					
ALL OTHERS	DEC. DIM. ± .005	DRILL, PUNCH, COMMERCIAL STOCK SIZES AND MANUFACTURERS TOLERANCES ARE NOT INCLUDED.					
	FRAC. DIM. ± 1/64						
	ANGULAR DIM. ±						

DRAWN: *A. Gabel*
 CHECKED: *JAD 11/6/52*
 ELEC. DES. APP.:
 MECH. DES. APP.:
 FINAL APPROVAL: PM-139